

iFLEX2 + iSCOUT expert compact

LMI system for
Grove RT / TM



Contents

General Information	1
Warnings	2
System Description	3
What's wrong?	4
Angle sensing	5
Length sensing	6
Pressure sensing	7
...	

Service Manual

Issue 8/2007 Rev. A

This document is listed under Order No.
50 650 69 0101e (Grove RT-TM)

TABLE OF CONTENTS

1	General Information.....	5
2	Warnings.....	5
3	Description Of The System.....	6
3.1	Description of system function.....	6
3.2	Description Of A Can Bus System.....	6
3.3	Description of the System Components	7
4	What's Wrong?	8
4.1	I have an error code indicated on the console	8
4.2	The displayed angle does not match the actual boom angle	8
4.3	The displayed length does not match the actual boom length	8
4.4	The displayed slewing does not match the actual slewing angle.....	8
4.5	The displayed load does not match the actual load	8
4.6	The console display is blank.....	8
4.7	I have an A2B problem	8
4.8	I Have A CAN-Bus Problem.....	8
4.9	I need to identify a spare part	8
4.10	I have noticed water in some part of the system	8
5	Angle Sensing.....	9
5.1	Angle sensing error - flow chart.....	10
6	Length Sensing.....	12
6.1	Length sensing error - flow chart.....	13
7	Pressure Sensing	15
7.1	Pressure sensing error - flow chart.....	15
8	Slewing Sensing	16
8.1	Slew sensing error - flow chart	17
9	Load sensing.....	18
9.1	Load sensing error - flow chart.....	18
10	No console display	19
11	A2B Problem	20
12	CAN-Bus communication	21
12.1	E61.....	21
12.1.1	E61 - Flow Chart.....	22
12.2	E62.....	23
12.3	E63.....	23
12.4	E64.....	23
12.4.1	E64 - Flow Chart.....	24
12.5	E65.....	24
13	Troubleshooting a sensor problem using the display.....	25

14	Drawings	28
14.1	Components of the LMI system PAT iFLEX2 with iSCOUT expert compact	28
14.2	Block Diagram.....	29
14.3	Electrical System Diagram Standard System.....	30
14.3.1	Central Unit, Overview	30
14.3.2	Central Unit, Detail A.....	31
14.3.3	Central Unit, Detail B.....	32
14.3.4	Sensors Wiring (page 2)	33
14.3.5	Console Wiring (page 3)	34
14.3.6	Crane Interface RT530-2 / RT540E (page 4)	35
14.3.7	Crane Interface RT600E / RT700E / RT875E (page 4).....	36
14.3.8	Crane Interface TM500E-2 (page 4).....	37
14.4	Main Central Unit Connector.....	38
14.4.1	Cable Reel (LG152/0056) Wiring Diagram	39
14.4.2	Cable Reel (LWG520/0002) Wiring Diagram	40
14.4.3	Luffer Extension Wiring Diagram	41
15	Sensor Calibration	43
15.1	Activating the Service Screen for Sensor Calibration	43
15.2	Zero-setting the Pressure Inputs	44
15.3	Zero-setting the slewing inputs	45
15.4	Length Sensor Calibration Procedure.....	46
15.4.1	Cable Reel Length Cable Replacement Procedure.....	49
15.5	Angle Sensor Calibration Procedure	50
16	Error Codes	53
17	Troubleshooting Moisture	58
17.1	Water Ingress.....	58
17.2	Condensation	59

The manufacturer reserves the right to modify the contents of this manual without notice. Hirschmann will not be liable for errors contained in this manual or for incidental or consequential damages in connection with the furnishing, performance, or use of this manual. This document contains proprietary information, which is protected by copyright, and all rights are reserved.

No part of this document may be photocopied, reproduced, or translated to another language without the prior written consent of Hirschmann.

Hirschmann reserves proprietary rights to all drawings, photos and the data contained therein. The drawings, photos and data are confidential and cannot be used or reproduced without the written consent of Hirschmann. The drawings and/or photos are subject to technical modification without prior notice.

All information in this document is subject to change without notice.

1 GENERAL INFORMATION

This service manual is designed to assist a service or maintenance person in identifying system problem areas or malfunctions. A digital voltmeter with the capability to measure current will be required, along with standard maintenance and service tools.

NOTE: Knowledge of how to use a voltmeter to measure both voltage and current is assumed.

REFERENCE: For system operation, refer to the consoles operator's manual 50 650 19 0101e.

2 WARNINGS

The LMI is an operational aid that warns a crane operator of approaching overload conditions and over hoist conditions that could cause damage to equipment and personnel.

The device is not, and shall not be, a substitute for good operator judgment, experience and use of accepted safe crane operating procedures.

The responsibility for the safe crane operation shall remain with the crane operator who shall ensure that all warnings and instructions supplied are fully understood and observed.

Prior to operating the crane, the operator must carefully and thoroughly read and understand the information in this manual to ensure that he knows the operation and limitations of indicator and crane.

Proper functioning depends upon proper daily inspection and observance of the operating instructions set forth in this manual. Refer to Section 6. *Pre-Operation Inspection and Calibration Verification* of the operator's manual.



The LMI can only work correctly, if all adjustments have been properly set. For correct adjustment, the operator has to answer thoroughly and correctly all questions asked during the setup procedure in accordance with the real rigging state of the crane. To prevent material damage and serious or even fatal accidents, the correct adjustment of the LMI has to be ensured before starting the crane operation.

3 DESCRIPTION OF THE SYSTEM

3.1 Description of system function

The iFLEX2 system is a CAN bus system made up of a central microprocessor unit, operating console, length/angle sensor, pressure transducers, and anti-two block switches. All components and sensors are equipped with CAN bus controllers.

The PAT Load Moment Indicator system operates on the principle of reference/real comparison. The real value, resulting from the pressure measurement is compared with the reference data, stored in the central processor memory and evaluated in the microprocessor. When limits are reached, an overload warning signal is generated at the operator's console. At the same time, the aggravating crane movements, such as hoist up, telescope out and boom down, will be stopped.

The fixed data regarding the crane, such as capacity charts, boom weights, centers of gravity and dimensions are stored in memory chips in the central processor unit. This data is the reference information used to calculate the operating conditions.

Boom length and boom angle are registered by the length/angle sensor, mounted inside the cable reel, which is mounted on the boom. The boom length is measured by the cable reel cable, which also serves as an electrical conductor for the anti two-block switches.

The crane load is measured by pressure transducer block attached to the piston and rod side of the hoist cylinders.

The interactive user guidance considerably simplifies the input of operating modes as well as the setting of geometry limit values.

3.2 DESCRIPTION OF A CAN BUS SYSTEM

CAN stands for "Controller Area Network". Its intended use is as a serial bus system for a network of controllers. Each controller connected through a CAN chip is called a "node" and is mostly used to acquire data from a sensor. All nodes are connected to a common bus and all nodes are able to simultaneously read the data on that bus. Also, all nodes are able to transmit data on that bus however only one node at a given time has write access to the bus. If the message is relevant, it will be processed; otherwise it is ignored. The unique identifier also determines the priority of the message. The lower the numerical value of the identifier, the higher the priority.

The cable bus is a twisted pair of shielded wire. Data can be transmitted in blocks from 0-8 bytes at a maximum transfer rate of 1 Mbit/s for networks up to 40 meters. For longer network distances the maximum transfer rate must be reduced to 50 Kbit/s for a 1 km network distance. CAN will operate in extremely harsh environments and the extensive error checking mechanisms ensure that any transmission errors are detected.

3.3 DESCRIPTION OF THE SYSTEM COMPONENTS



Pressure Transducer: The pressure transducer converts hydraulic pressure into an electric signal. A pressure transducer block houses two transducers, CAN bus converter board, and two bus connectors. One pressure transducer is connected to the piston side of the lift cylinder and the other to the rod side.



The Length-Angle Transducer: The length-angle sensor (LWG), often referred to as the “cable reel”, is a combination of two transducers in one box, installed on the base section of the boom. It measures the length and the angle of the boom.

A reeling drum drives a potentiometer, which is the length transducer. Part of the length transducer circuit is the length cable on the drum, which is a multi-conductor cable. It is connected to the anti-two-block switch at the boom head and to a slip ring body in the LWG.

The angle transducer is a potentiometer driven by a weighted pendulum that is oil damped. Both length and angle transducer are connected to a CAN bus controller board, which is connected to the bus system.



Anti-Two-Block Switch: The anti-two-block switch monitors the load block and its relationship with the head of the boom. In working condition the switch is closed. When the load block strikes the weight the circuit opens, disengaging a relay output to the lock out solenoid valves, where applicable. To check the cable for damage, (short circuit to ground) there is a 4.7k resistor between ground and the contact of the switch, to give a signal back to the central unit. The weight at the anti-two-block switch keeps the switch closed until the load block strikes it.



Console: The graphic console displays all geometrical information such as length and angle of main boom, working radius and head height of the boom. It also displays the actual load and the maximum load permitted by load chart. Furthermore, it has an alarm horn, a warning light for overload, and a pre-warning light. The graphic display allows for a simple interactive configuration setup, as well as sensor calibration (zero adjustment), and troubleshooting sensor output screen. The console has a warning light for anti-two-block conditions and an override switch for overload or anti-block condition.

Refer to Operator’s Handbook for detailed operation of the console.



Central Unit: Inside the central unit there is a CPU. The central unit has a hard mounted connector for all signals. A status indicator (7-segment display) shows operation and error codes.

Slew Potentiometer: This component is not supplied by PAT/Hirschmann. It is part of the electrical swivel (slip ring assembly). The potentiometer has two wipers which are used to determine the slewing angle (rotational positioning) of the super structure in relation to the carrier. The slew input to the central unit is not a CAN signal, but rather two 4..20mA analog signals.

4 WHAT'S WRONG?

So, what's wrong? Assuming you are reading these pages because of some kind of problem with the PAT system, let us try to guide you quickly to solving the problem. In most cases, your problem will fall under the following categories:

4.1 I HAVE AN ERROR CODE INDICATED ON THE CONSOLE

Please go to section [Error Codes](#).

4.2 THE DISPLAYED ANGLE DOES NOT MATCH THE ACTUAL BOOM ANGLE

Start in section [Angle Sensing](#) to check the indicated angle.

4.3 THE DISPLAYED LENGTH DOES NOT MATCH THE ACTUAL BOOM LENGTH

Start in section [Length Sensing](#) to check the indicated length.

4.4 THE DISPLAYED SLEWING DOES NOT MATCH THE ACTUAL SLEWING ANGLE

Refer to section [Slewing Sensing](#) to check the slew sensor.

4.5 THE DISPLAYED LOAD DOES NOT MATCH THE ACTUAL LOAD

Please note that the indicated load is calculated by the system from the geometry information in the computer, the operator's selections, and all the sensor inputs. If the load display is off, it can therefore be due to an error in any or several of these inputs! Refer to section [Load sensing](#) to narrow down the source of your problem.

4.6 THE CONSOLE DISPLAY IS BLANK

If the console does not show any sign at all (no lights, no buzzer, no display), the problem is either in the wiring between console and central unit, or the console itself. Refer to section [No console display](#) for further troubleshooting.

4.7 I HAVE AN A2B PROBLEM

Please go to section [A2B PROBLEM](#)

4.8 I HAVE A CAN-BUS PROBLEM

Please go to section [CAN-Bus Communication!](#)

4.9 I NEED TO IDENTIFY A SPARE PART

Please go to the [Spare Part Listings!](#)

4.10 I HAVE NOTICED WATER IN SOME PART OF THE SYSTEM

Please go to section [Troubleshooting Moisture!](#)

5 ANGLE SENSING

The System measures the angle of the main boom of the machine with an angle sensor. The angle sensor is contained within the cable reel, located on the left side of the main boom.

Block Diagram

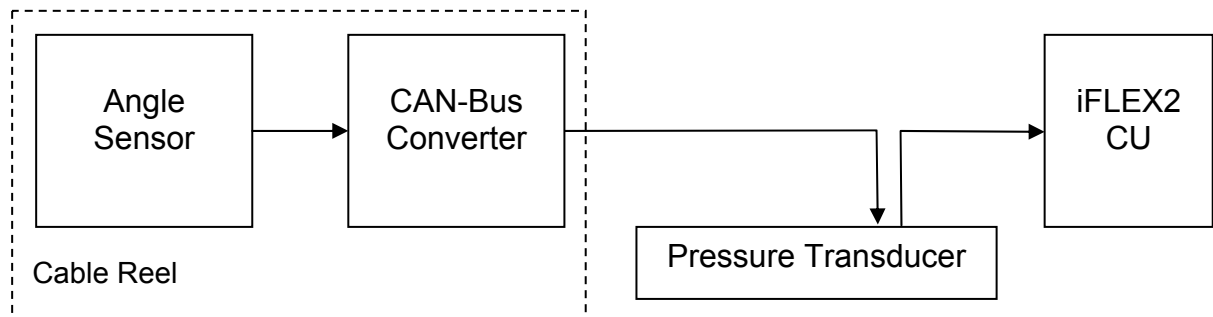

The signal runs from the angle sensor to the Can-Bus converter board, both located in the cable reel. From there, it travels as digital information on the CAN-Bus to the pressure transducer, which acts as a T-connector to the main CAN-Bus running to the central unit.

So, what do you do when you are having a problem with your angle read-out?

Start by verifying the angle display. Refer to the section [“Troubleshooting A Sensor Problem Using The Display”](#) to call up the sensor signal on your console display. The CAN-Bus is digital and as such will either transmit the signal correctly or not at all. If your readings are off, you have to determine what is causing the problem (reference the following flow charts).

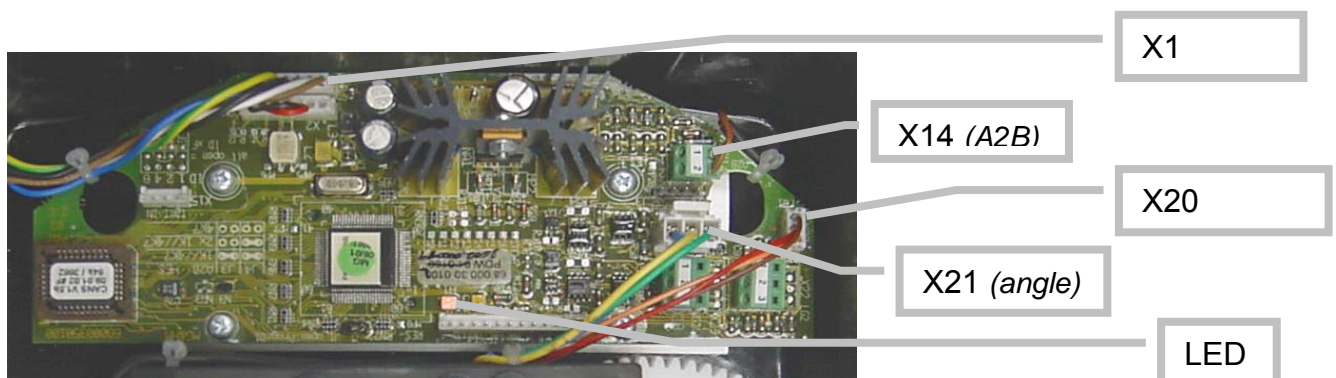

CAN-Bus electronics in cable reel

The angle sensor has a potentiometer built in that is driven by a pendulum. As the angle changes, so will the pendulum and with it the potentiometer’s axle. The converter board supplies a constant voltage of 5V to the angle sensor and in return monitors the voltage of the potentiometer. The terminal used is X21. The angle sensor is connected as follows:

Terminal X21	
1	+ 5V
3	Signal
5	GND

5.1 ANGLE SENSING ERROR - FLOW CHART

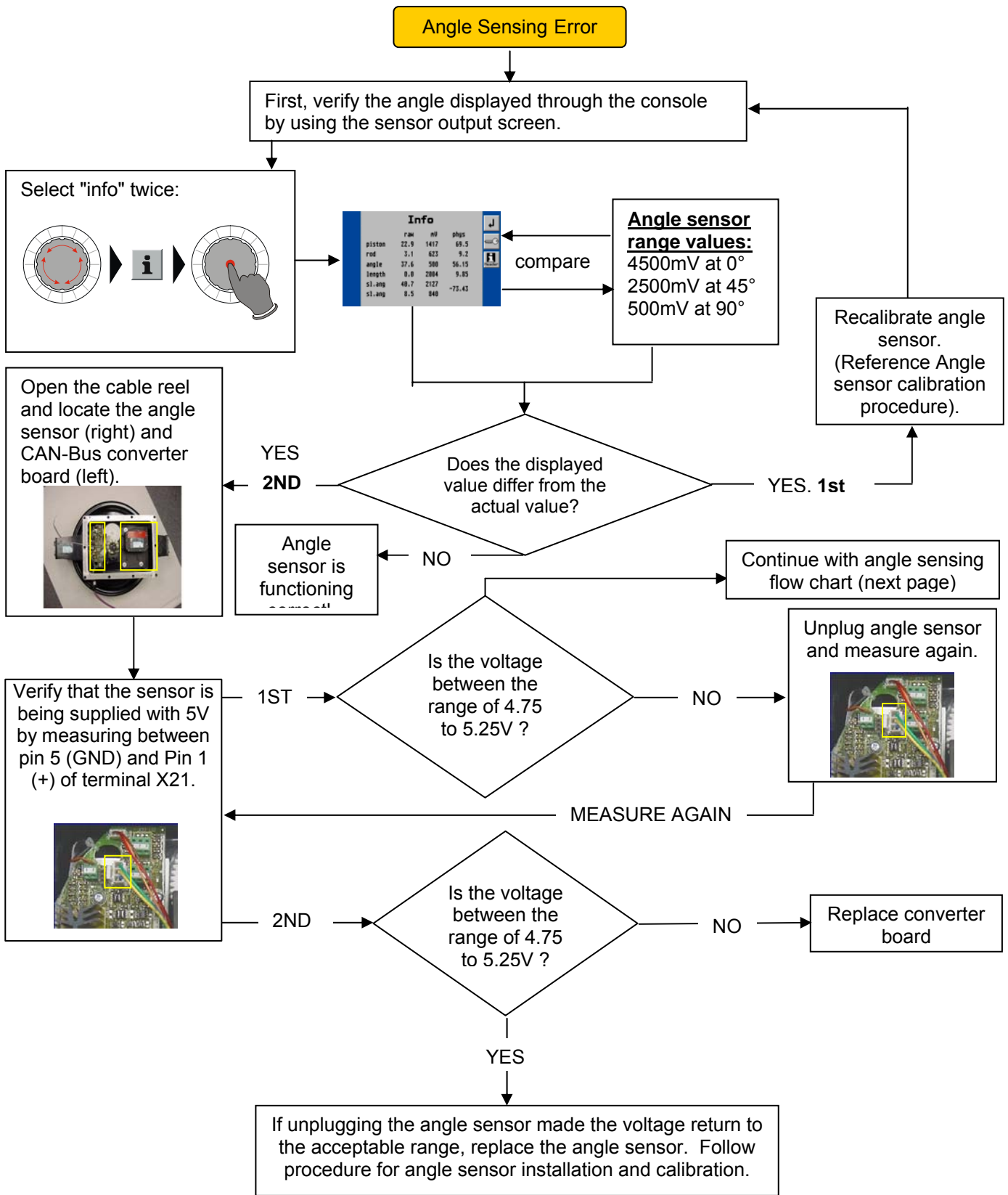

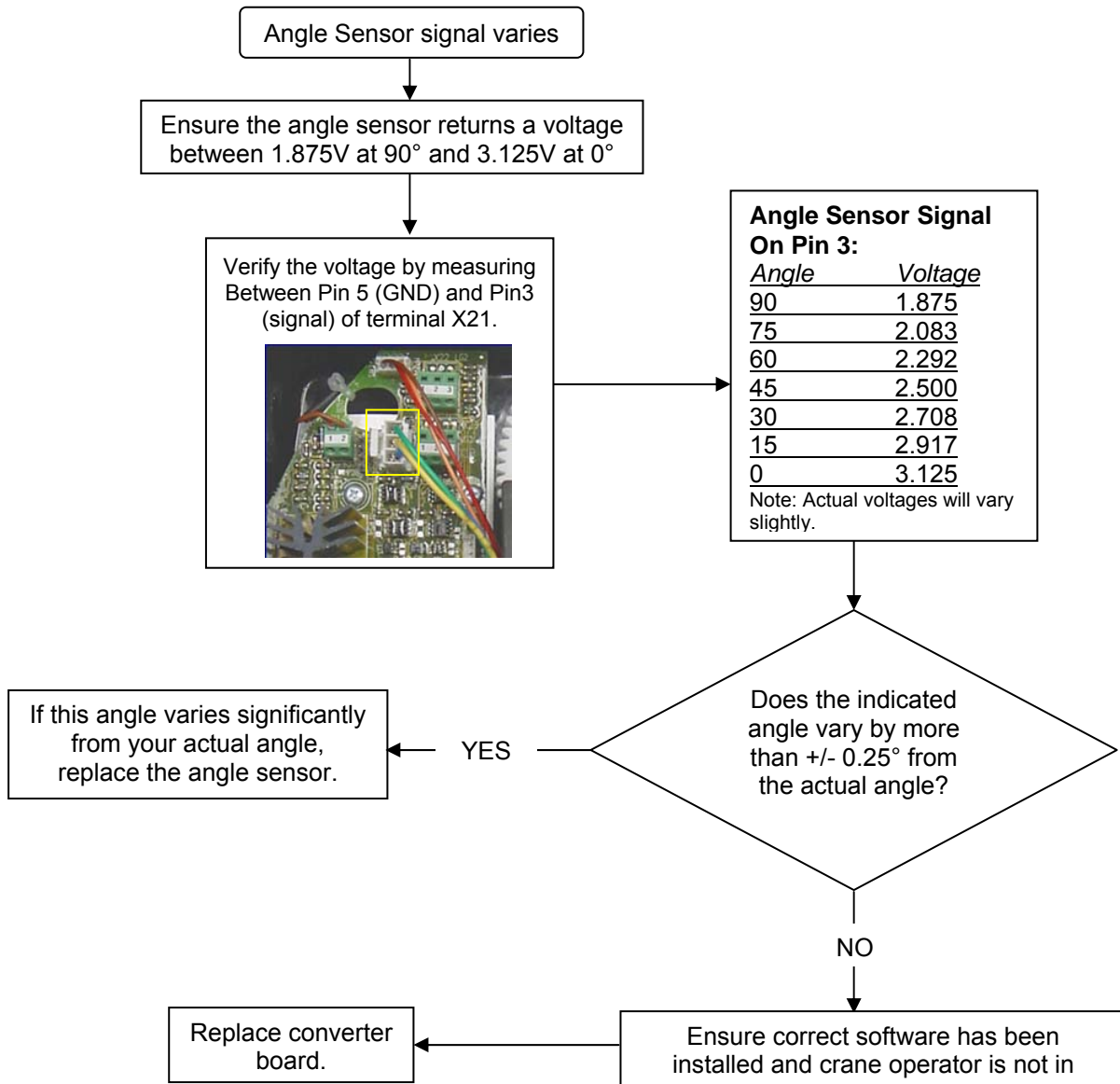

Note: If you need to determine the angle for voltages other than shown above, do so by using the following formula:

$$\text{Angle (degrees)} = 90 \text{ degrees} - ((\text{Voltage} - 1.875) * 72)$$

6 LENGTH SENSING

The system measures the length of the main boom of the machine with a length sensor. The length sensor is contained within the cable reel, located on the left side of the main boom.

Block Diagram

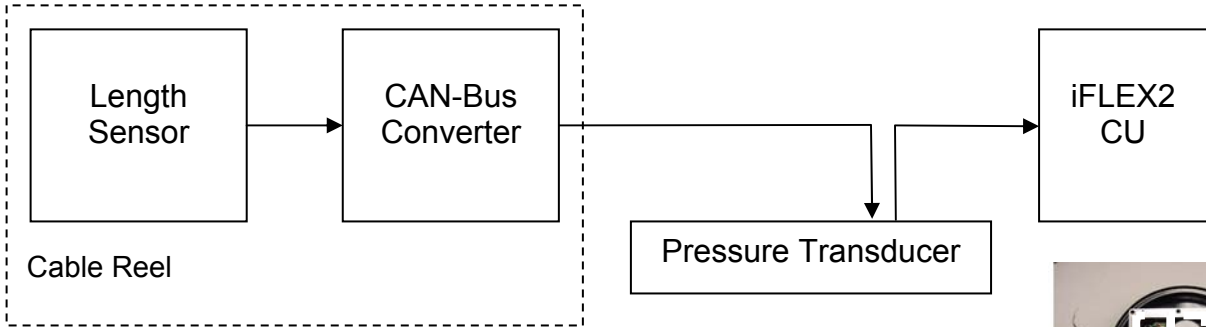

The signal runs from the length sensor to the CAN-Bus converter board, both located in the cable reel. From there, it travels as digital information on the CAN-Bus to the pressure transducer, which acts as a T-connector to the main CAN-Bus running to the central unit.

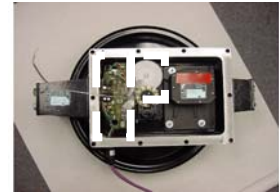

So, what do you do when you are having a problem with your length read-out?

Start by verifying the length display. Refer to the section “[Troubleshooting A Sensor Problem Using The Display](#)” to call up the sensor signal on your console display. The CAN-Bus is digital and as such will either transmit the signal correctly or not at all. If your readings are off, you have to determine what is causing the problem (*reference the following flow charts*).

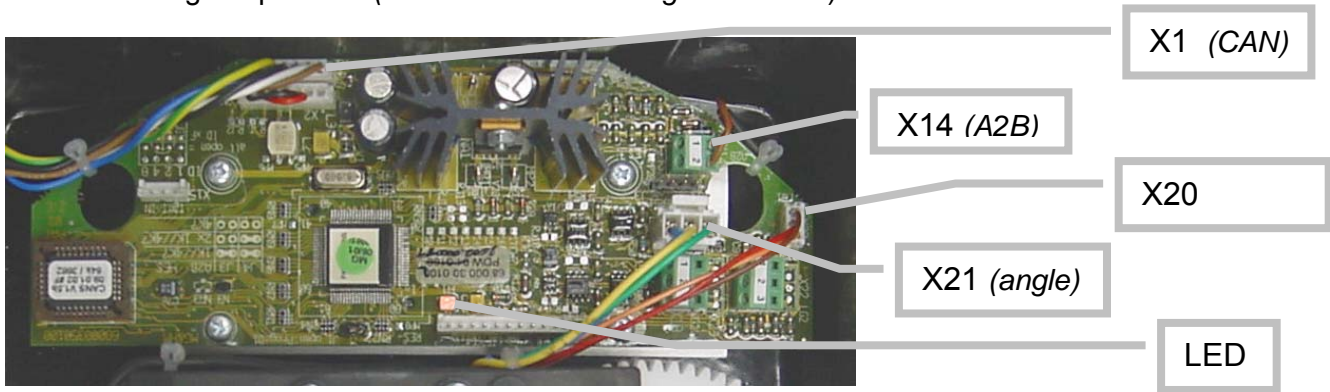

CAN-Bus electronics in cable reel.

The length sensor has a potentiometer built in that is driven by a gear drive from the cable drum. As the length changes, the cable drum will turn and with it the potentiometer’s axle. The converter board supplies a voltage of about 4.7V to the length potentiometer and in return monitors the output voltage of the potentiometer. The terminal used is X20. The length sensor is connected as follows:

Terminal X20	
1	+ (~ 4.8V)
3	Signal
5	- (~ 0.2V)

6.1 LENGTH SENSING ERROR - FLOW CHART

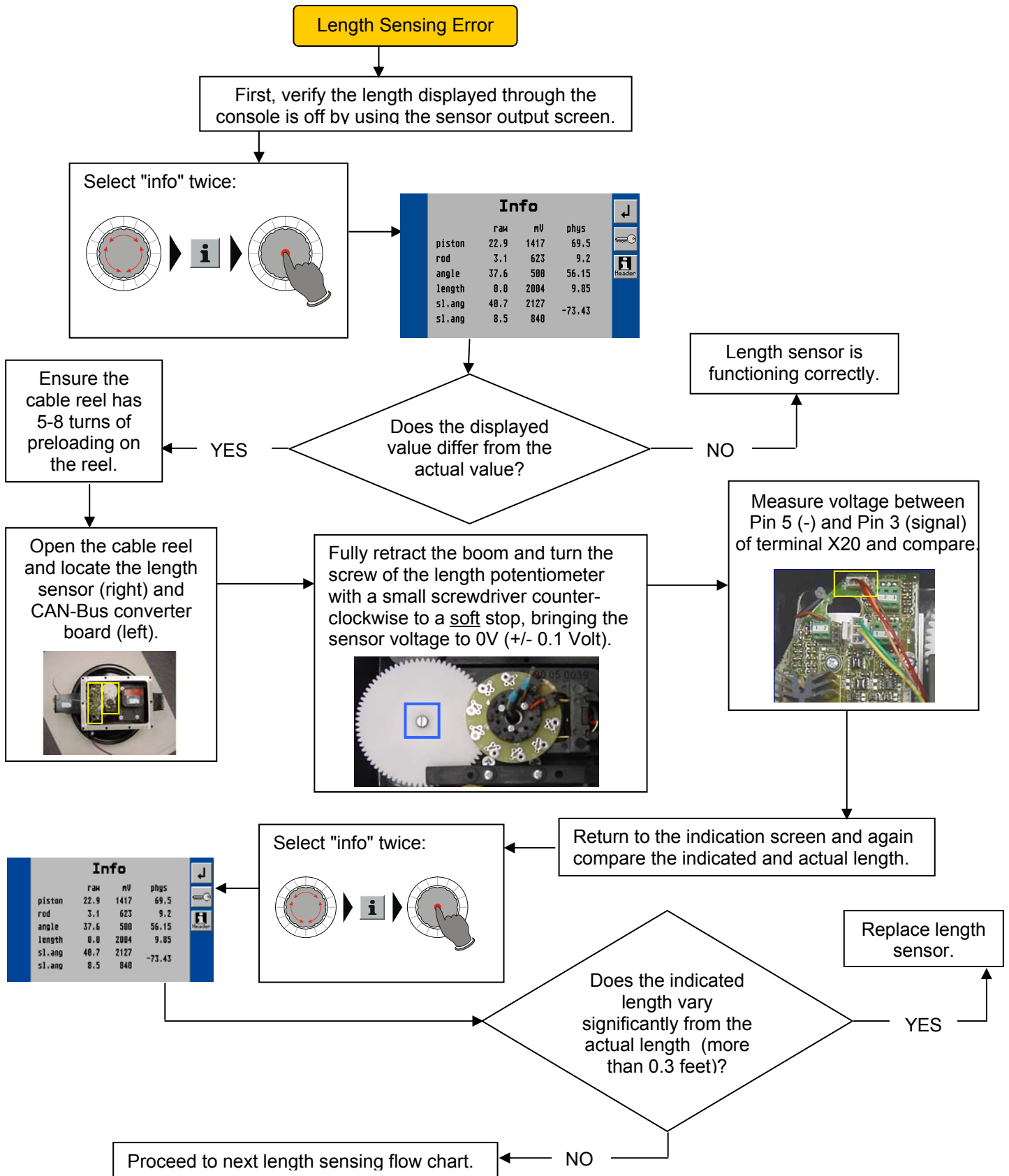

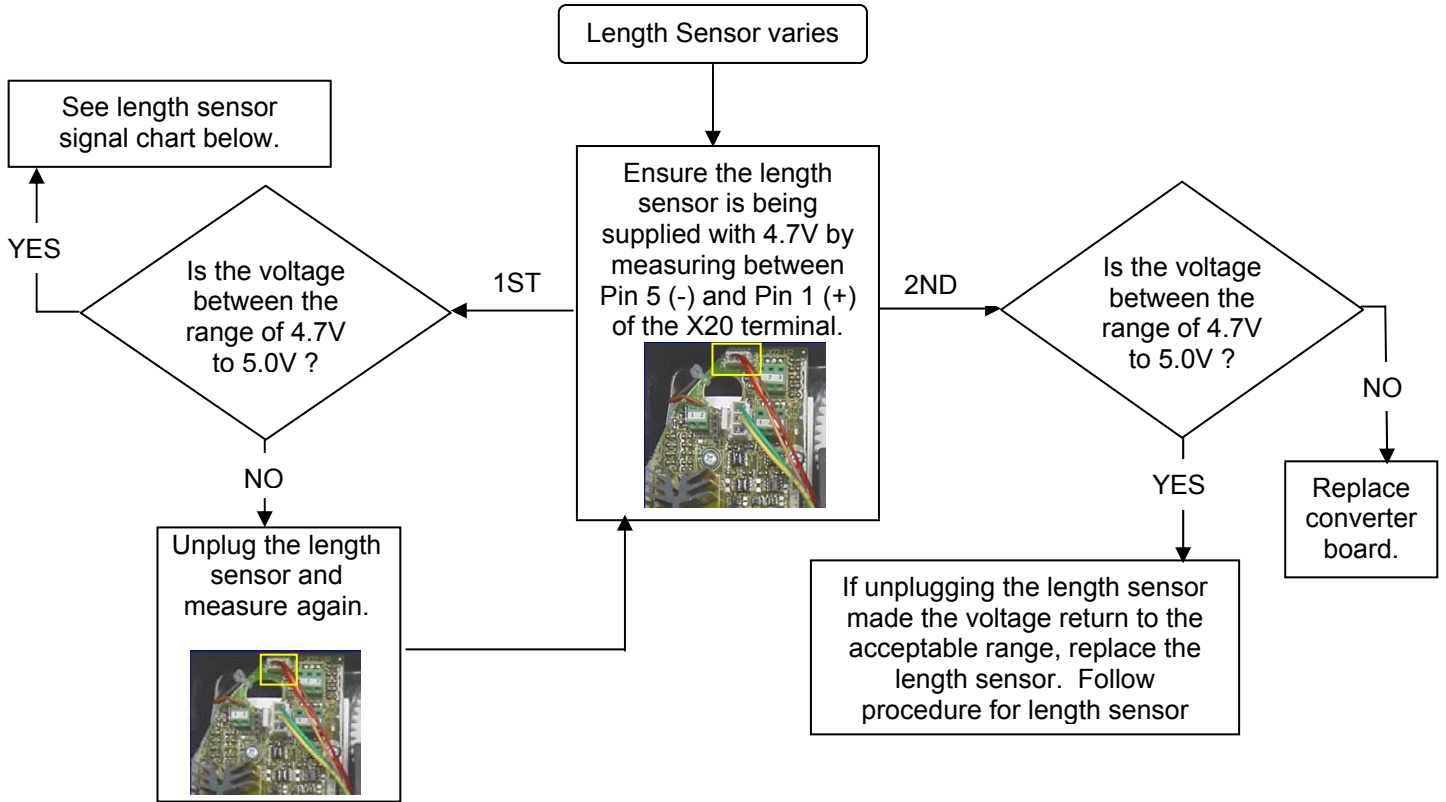

The length sensor returns a voltage between 0.16V at 0 turns of the length pot (= fully retracted) and 4.84V at 10 turns. How many turns you get at full extension depends on the gear ratio, the boom length, the length cable used and the spooling pattern, so we cannot provide a standard table for it.

What we can give you for trouble-shooting, however is the following table that shows the expected output voltage (measured between X20-5 and X20-3 Signal) for each complete turn of the length potentiometer. Note that this does not sync to the number of turns of the cable reel, though:

Length Sensor Signal on Pin 3		
Turns	Voltage X20-5 to X20-3	Voltage GND to X20-3
0	0.00	0.16
1	0.46	0.62
2	0.93	1.09
3	1.40	1.56
4	1.87	2.03
5	2.34	2.50
6	2.81	2.97
7	3.28	3.44
8	3.75	3.91
9	4.22	4.38
10	4.68	4.84

Note: Actual voltages will vary slightly.

For the boom control system, the length sensors are the same as described above with the exception of cable reel internals (location of hardware, wiring, and gear wheels). Refer to the LWG520 and LG152 spare part list for these differences.

7 PRESSURE SENSING

The System measures the pressure of the boom lift cylinder for both rod- and piston-side. Both sensors are contained within one box that also contains the electronics needed for amplification and creation of the CAN-Bus signal.

Block Diagram:

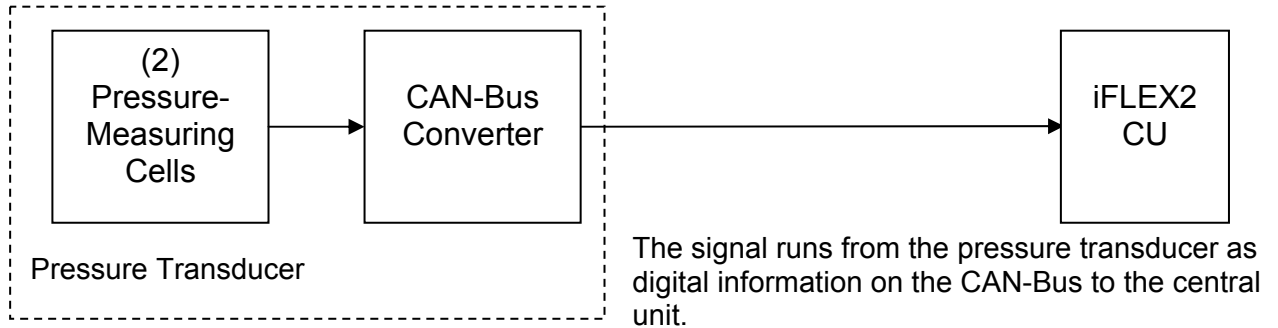

7.1 PRESSURE SENSING ERROR - FLOW CHART

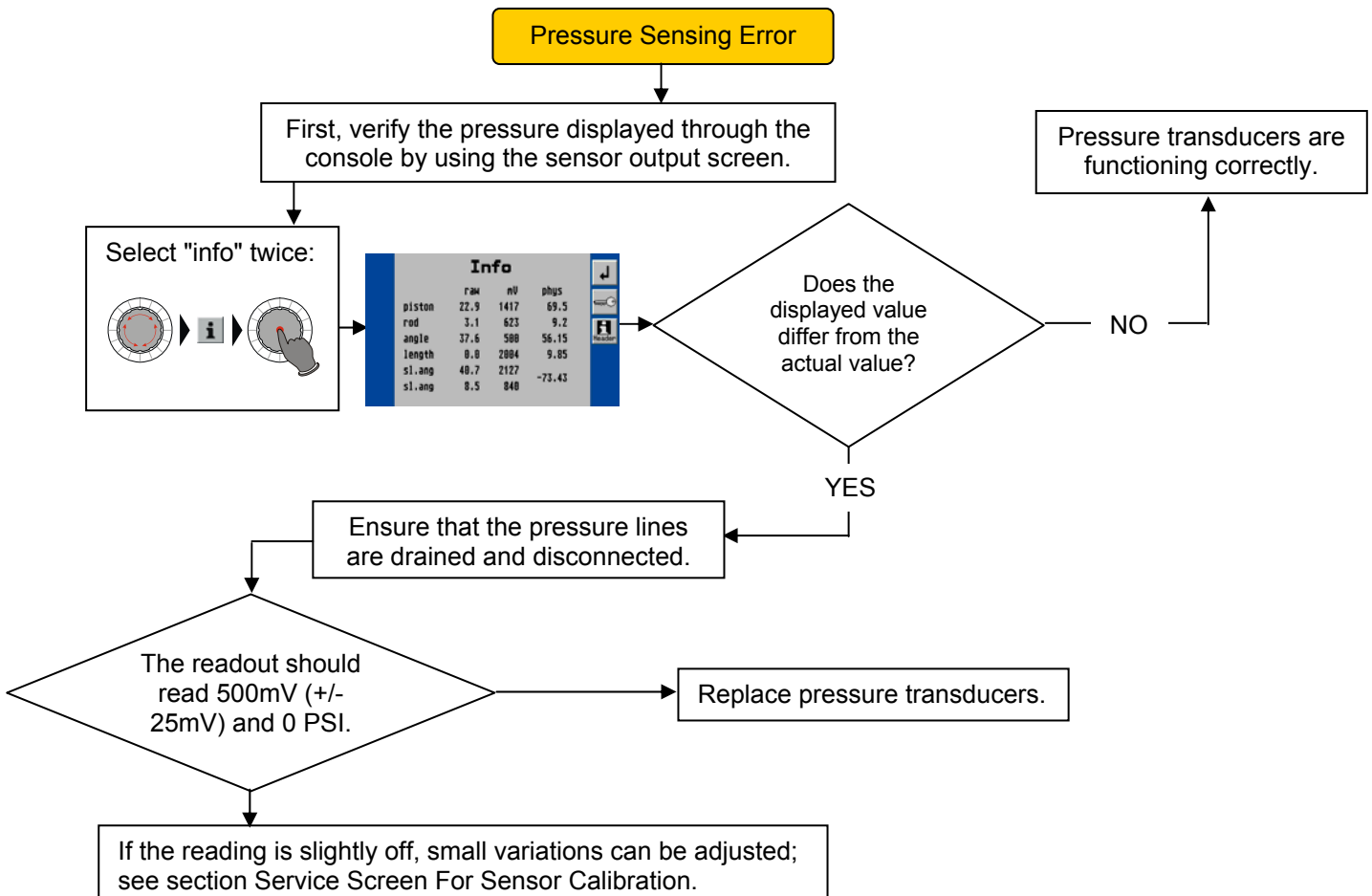

Note: After exchanging the pressure transducer block, both transducer channels need to be zeroed, see procedure [Zero-Setting The Transducer Inputs](#).

8 SLEWING SENSING

The system measures the slewing (rotational position) of the crane's upper with a slewing sensor. The slewing sensor is contained within the slip ring assembly.

Block Diagram

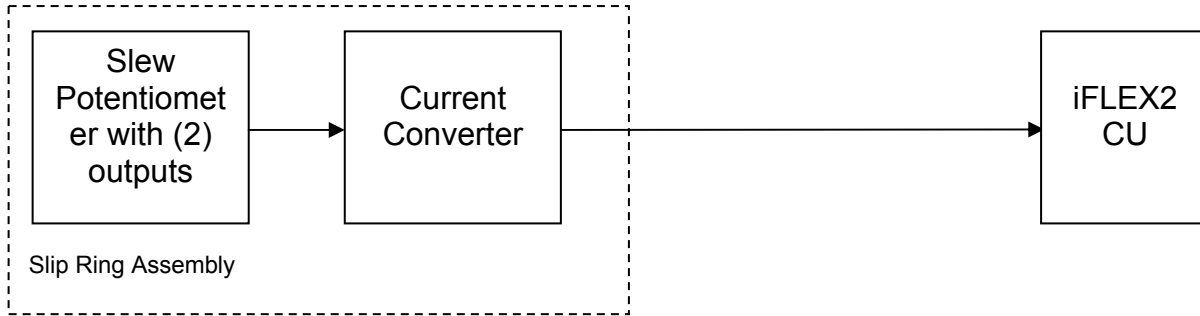

The slew potentiometer has two potentiometers built in that are driven by the slip ring axle. As the slewing angle changes, so will the axle and with it the potentiometer's outputs. Use the display screen by pressing 'i' (info) twice to show all sensor inputs.

The table to the right show measured millivolt reading for the slew potentiometer.

ANGLE (deg)	SL ANG 1 (mv)	SL ANG 2 (mv)
0.0	717	2161
30.3	1174	2645
60.0	1680	3150
89.9	2158	3595
120.1	2641	3141
150.1	3144	2639
180.0	3595	2161
-150.1	3144	1681
-120.1	2642	1180
-90.0	2160	718
-60.1	1681	1168
-30.0	1172	1680
0.0	718	2161

Modular Slew Pot - Voltage on Service Screen

The converter board is supplied with 12V from the central unit. The potentiometer and the board output two signals between 4 and 20mA that go to the central unit. You can measure them at the 12-pin crane interface connector.

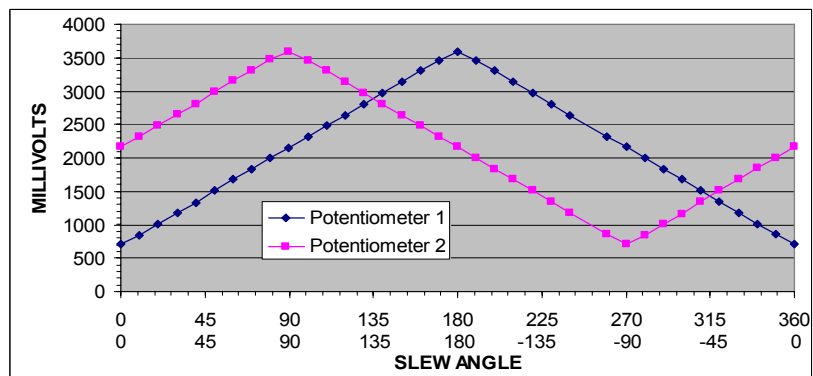

8.1 SLEW SENSING ERROR - FLOW CHART

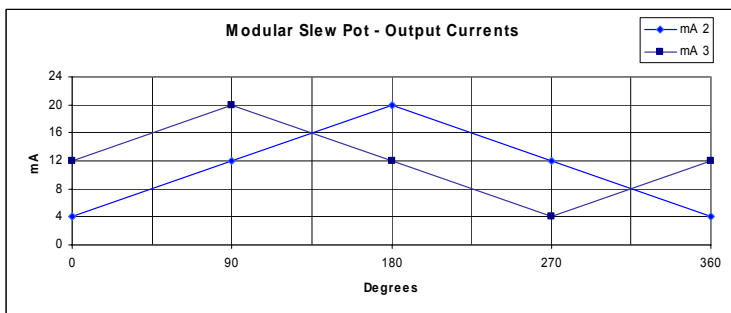
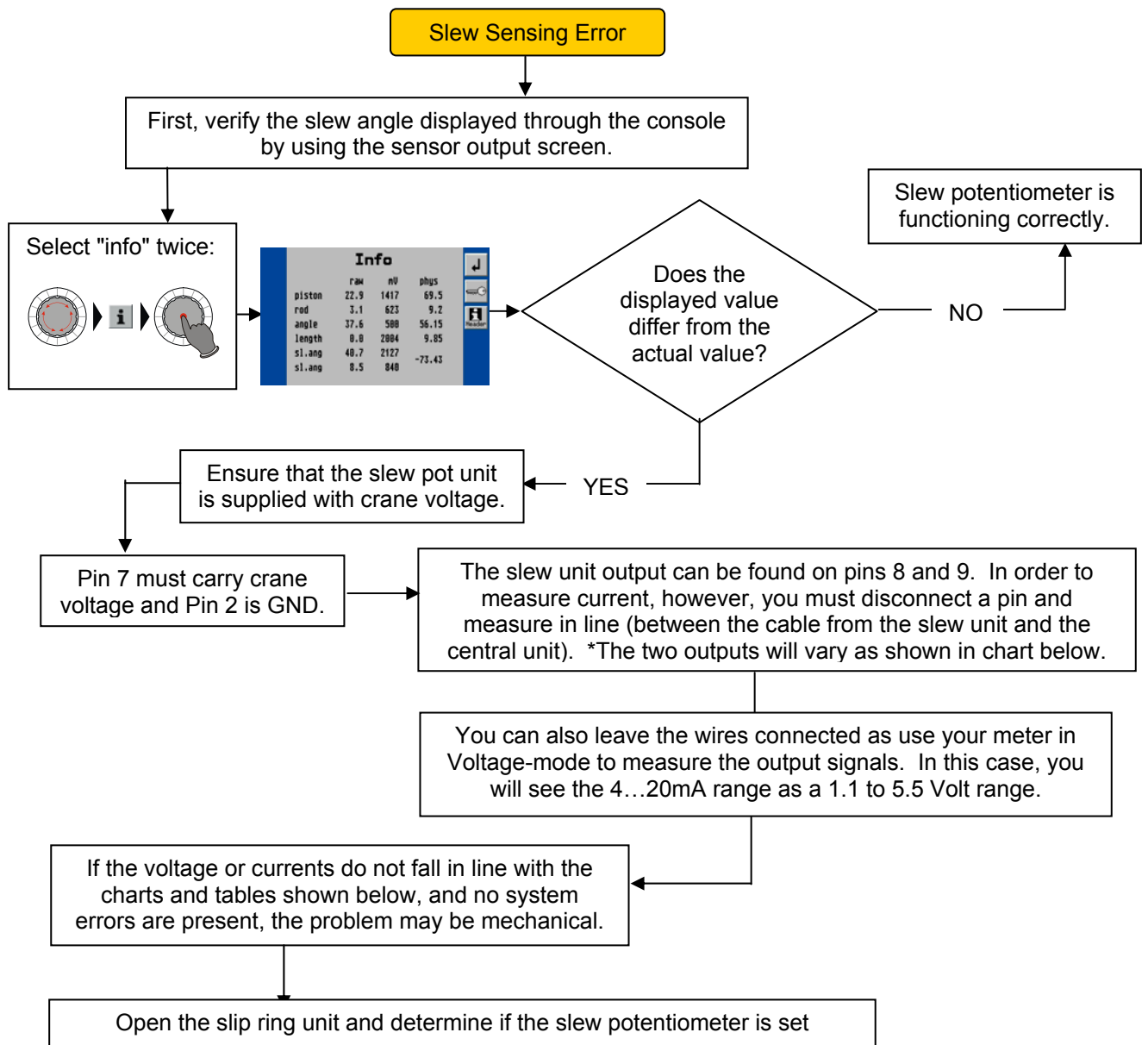

(When the crane is over front, you should see about 4mA in one channel (wire #2) and 12mA in the other channel (wire #3)).

9 LOAD SENSING

Please note that the load displayed by the LMI is not a direct measurement, but a calculated value that is based on a lot of factors. Outside of the measured values (sensors), those include:

- Operator settings such as:
 - Operating mode/configuration
 - Parts of Line/Reeving
- Rigging parts such as:
- Hookblock weight
- Sling weights, etc.
- Tip height (length of load line used)
- Boom weights
- Boom attachments such as
- Stowed jibs
- Auxiliary boom nose, etc.

9.1 LOAD SENSING ERROR - FLOW CHART

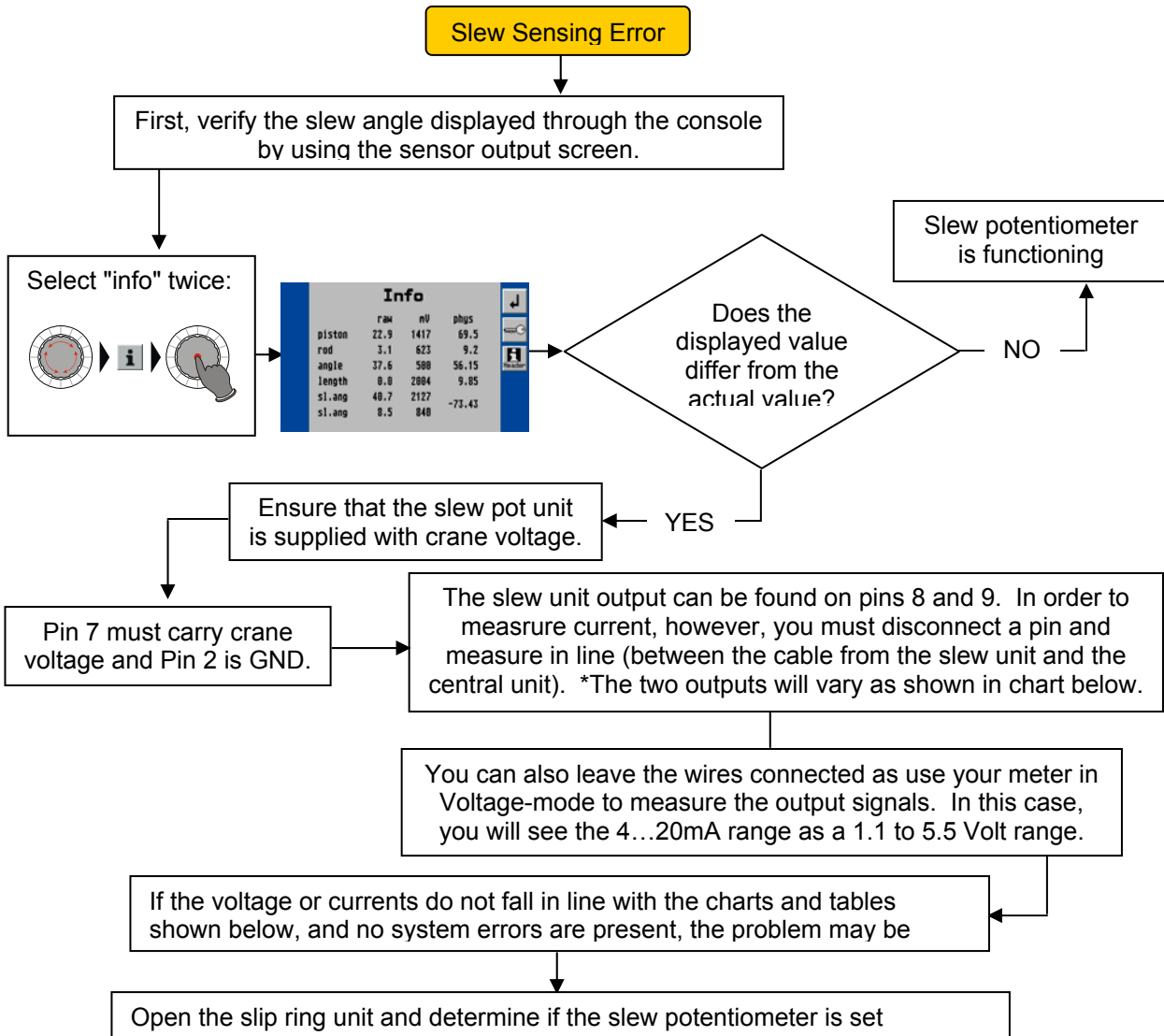

10 NO CONSOLE DISPLAY

If the console is not showing any lights, such as warning lights, backlighting, etc. it is most likely missing power. Start with the following:

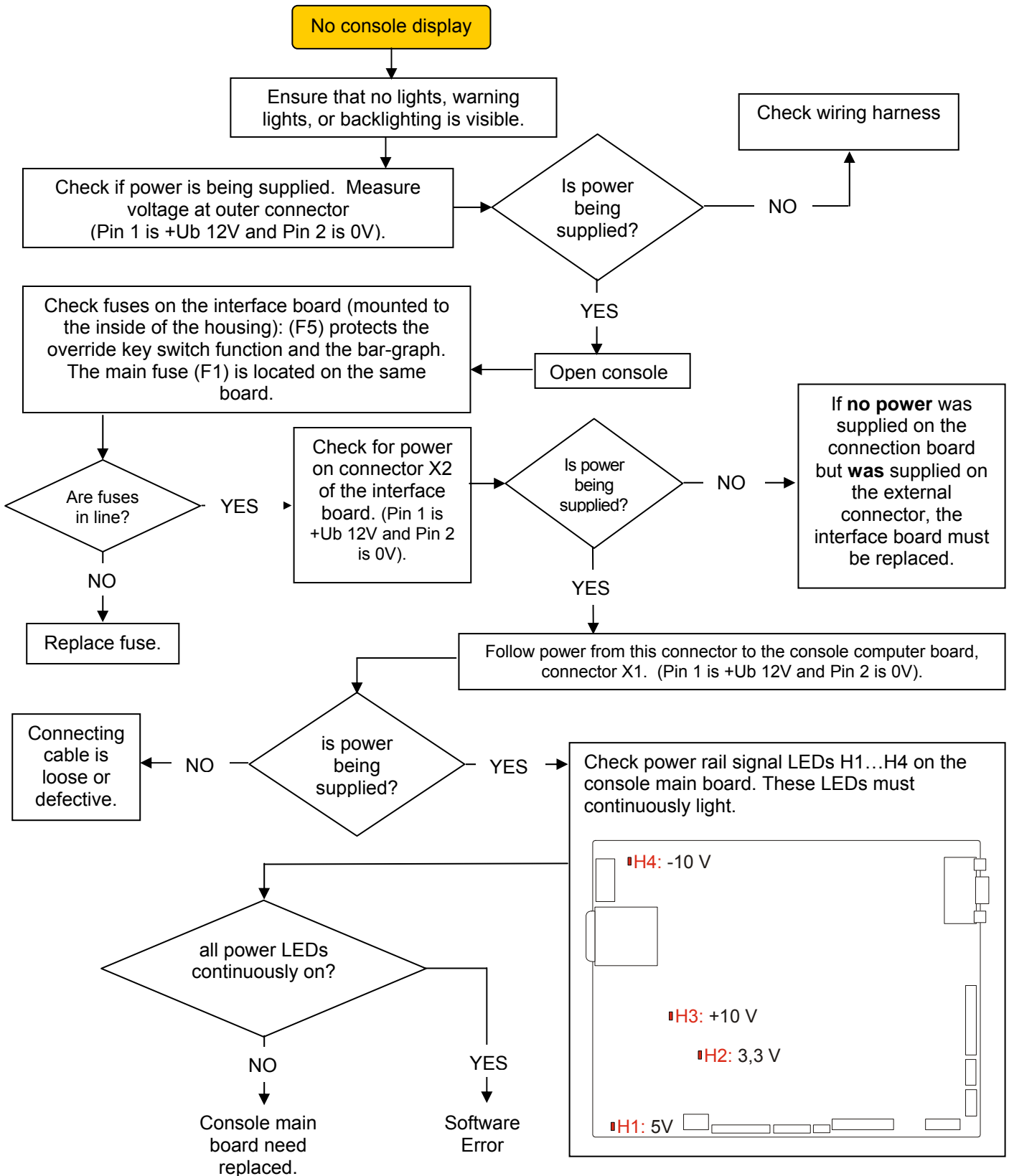

11 A2B PROBLEM

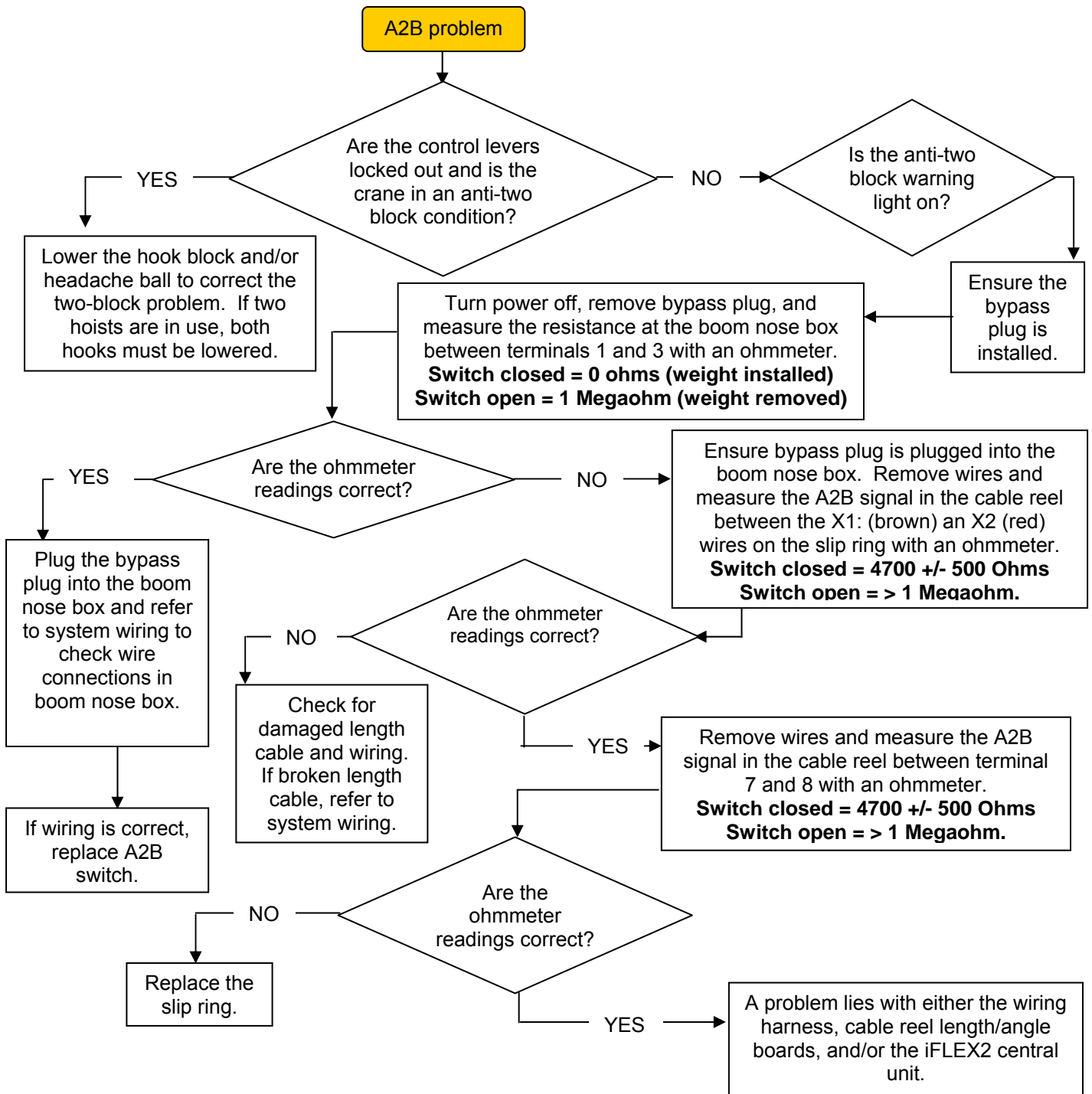

12 CAN-BUS COMMUNICATION

The System measures the length of the main boom, the angle of the main boom, the pressures of the lift cylinder, and the A2B state of the machine via a CAN-Bus connection. Since this is a digital bus connection, it is not possible to measure the signals on the bus with a multimeter. Instead, the LMI provides you with error codes that give you an indication of the bus state.

The error codes are one of the following:

- E61 Error in the CAN bus data transfer for all CAN units
- E62 Error in the can bus data transfer of the pressure transducer sensor unit
- E63 Error in the can bus pressure transducer sensor unit
- E64 Error in the can bus data transfer of the length/angle sensor unit
- E65 Error in the can bus length/angle sensor unit

Block Diagram

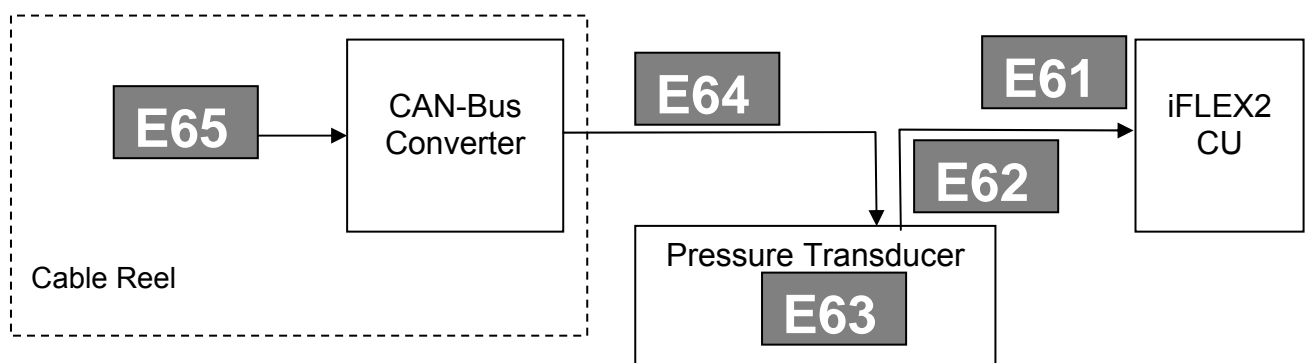

The block diagram tries to clarify that: If the CU does not see any CAN-Bus component, it will report an E61. If it sees only the cable reel, it will report an E62 (pressure transducer missing). If it sees only the pressure transducer, it will report an E64 (cable reel missing). E63 means that the pressure transducer is available, but is reporting an internal error. E65 means that the cable reel unit is available, but is reporting an internal error.

So, what do you do when you are having a problem with one of those codes?

12.1 E61

In case of an E61, start by connecting the two cables on the transducer block together. If an E62 appears, the transducer block must be replaced. If an E61 appears, reconnect the cable from the from the central unit to the transducer block. At this point, if an E61 still appears check your cabling. You can verify that power is being supplied to the sensor by testing the CAN connectors per this layout:

Connector M12, 5 contacts
 Pin Layout (CiA DR-303-1 7.2)

Pin 1 Shield
 Pin 2 + U_b
 Pin 3 Ground
 Pin 4 CAN High
 Pin 5 CAN Low



Measure between pins 3 and 2 for crane voltage. If you see voltage, check all pins for continuity.

The iFLEX2 must be replaced if this cable is functioning correctly. If the E61 error code has become an E64, connect the cable reel can bus cable to the transducer block and remove the can bus connector at the cable reel. If this causes an E61 to appear, the can bus cable between the cable reel and transducer block must be replaced. If an E64 remains, use the Ohm-meter to check the connector in the cable reel. Either the connector has failed or the can bus converter boards must be replaced.

12.1.1 E61 - Flow Chart

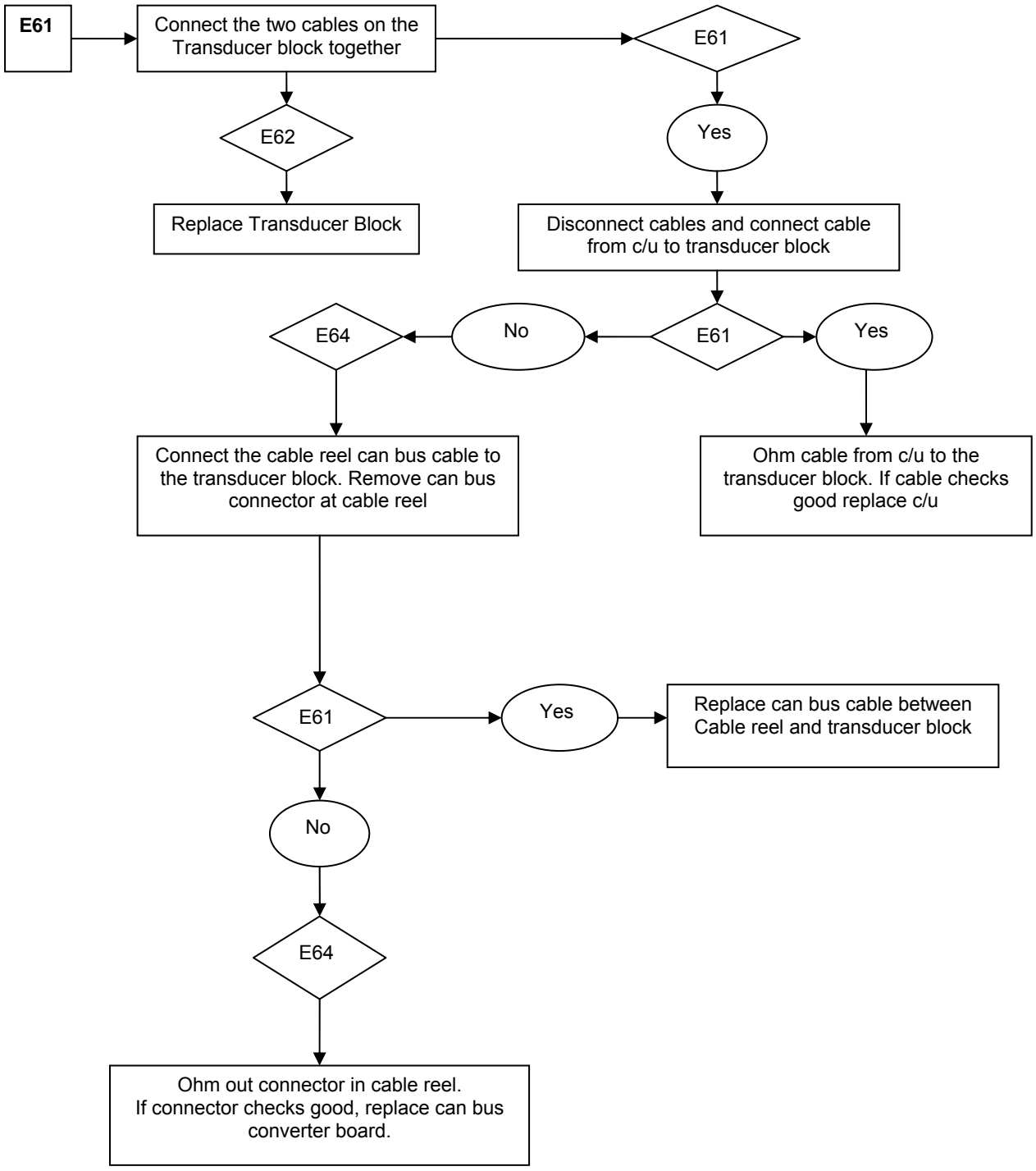

12.2 E62

In case of an E62 the CU is reporting no signal from the pressure transducer. Start by checking your cabling between CU and pressure transducer, even though it is not very likely that there is a problem with it since the same cable carries also the signals from the cable reel and those appear to be fine. You can verify that power is being supplied to the sensor by testing the CAN connectors per the above pin layout. If you are sure that the sensor is being supplied, you have to replace the pressure transducer.

12.3 E63

In case of an E63, the pressure transducer is reporting an internal problem. You cannot troubleshoot any further, but need to replace the pressure transducer.

12.4 E64

In case of an E64, the CU is reporting no signal from the cable reel unit. Start by connecting the two cables on the transducer block together. If an E62 occurs, the transducer block must be replaced. If an E61 occurs, measure the cable from the transducer block to the cable reel with an Ohm-meter. Check all pins of the CAN bus cable for continuity and cross-check for short circuits. If the continuity check fails, the cable must be replaced. If the cable appears to be fine, next check the connector at the cable reel. You can verify that power is being supplied to the sensor by testing the CAN connectors per the pin layout (see E61). Replace the connector if this check fails. If the connector checks properly, the board in the cable reel might be defective.

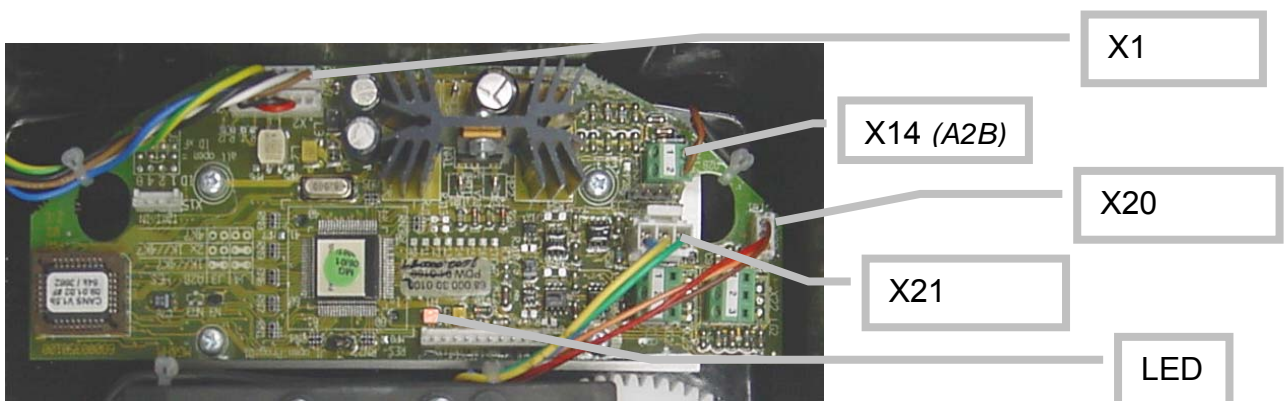

CAN-Bus electronics in cable reel.

X1 Pin	CAN
1	CAN_SHLD
2	CAN +UB
3	CAN GND
4	CAN_H
5	CAN_L

12.4.1 E64 - Flow Chart

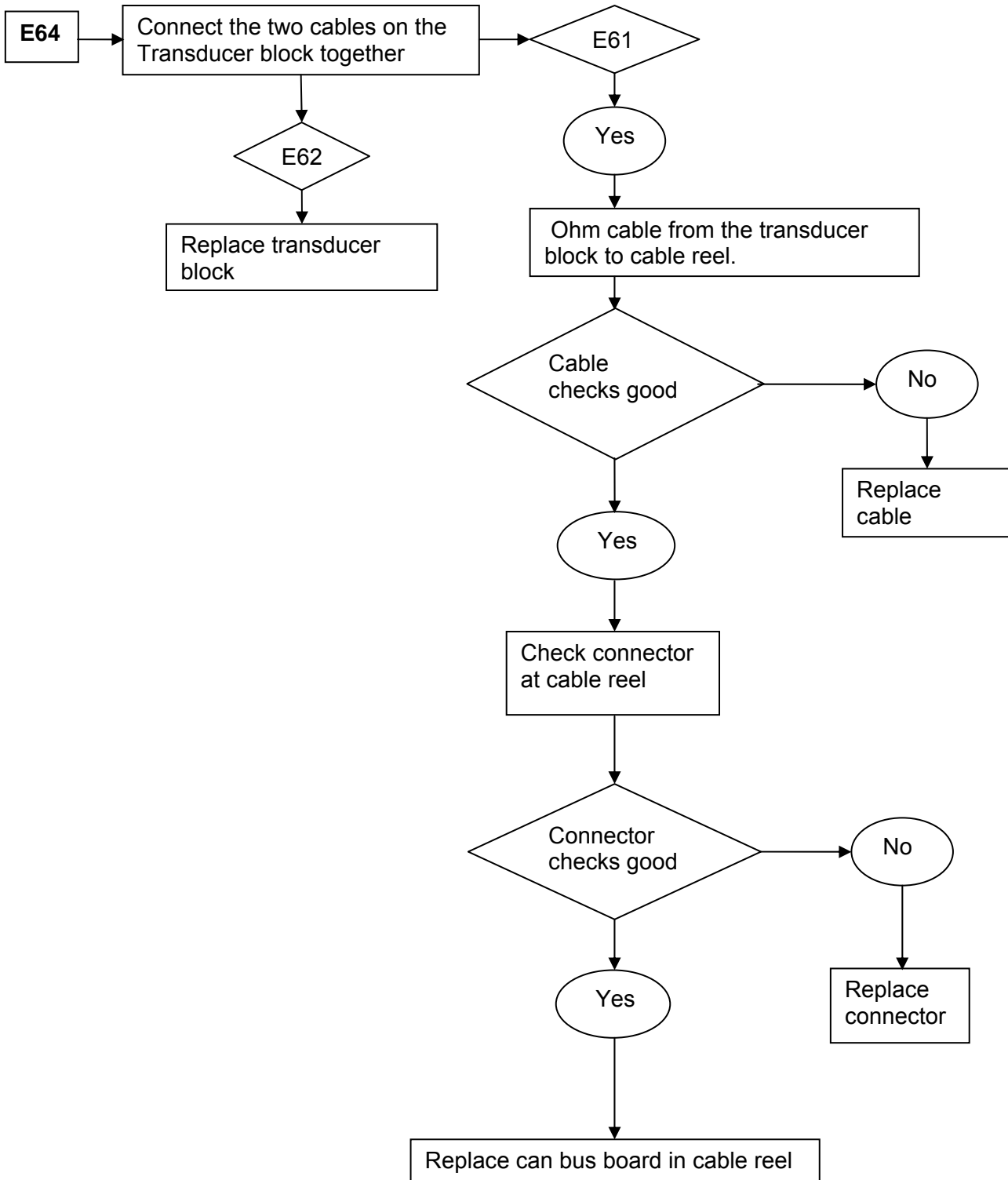

12.5 E65

In case of an E65, the cable reel is reporting an internal problem. In most cases, this will be an angle sensor, length potentiometer or A2B wiring. Go to those chapters ([Angle Sensing](#), [Length Sensing](#), [A2B PROBLEM](#)) to continue trouble shooting.

13 TROUBLESHOOTING A SENSOR PROBLEM USING THE DISPLAY

To determine whether there is a problem with a sensor, the system has “sensor value screen” built in to make trouble-shooting easier. This is the right place to start if you are suspecting a problem with a sensor (and you don’t have an error code displayed).

- to access the sensor output screen, select the “INFO” button twice

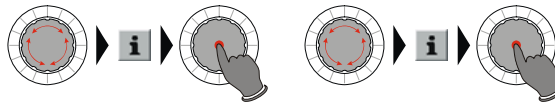

Info			
	raw	mV	phys
piston	22.9	1417	69.5
rod	3.1	623	9.2
angle	37.6	500	56.15
length	0.0	2004	9.85
sl.ang	40.7	2127	
sl.ang	8.5	840	-73.43

- to review software version information, select the “INFO” and then the “INFO-Haeder” button once

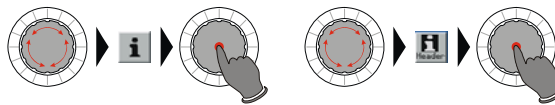

Node: 1	
PAT-PDC D4 DISPLAY System Software -	
V 2.61- (c) 1990-2007 HAC GmbH Ettlin	
gen	

I/O-configuration MOVGA - V1.00 HAC G	
nbH - (c) 16.11.2006	

CAN mapping n1003 Grove LMI with IF	
lex2-System	

Grafik: Grove RT 530 expert compact -	

The screen will show all sensor inputs as in the example below. For each sensor, an equivalent voltage is shown in millivolts, along with the physical sensor value that that voltage refers to. Pressure sensors are shown with physical values of [bar], angle sensors and slew sensors in degrees and length sensors in feet (or meter for metric charts).

Info			
	raw	mV	phys
piston	22.9	1417	69.5
rod	3.1	623	9.2
angle	37.6	500	56.15
length	0.0	2004	9.85
sl.ang	40.7	2127	
sl.ang	8.5	840	-73.43

The values shown in the screen here are just examples of actual values. Refer to the table listed below for actual value ranges.

If you suspect a sensor error or problem with a sensor, compare the indicated physical value of the sensor on the display screen with the real value, i.e. length, angle, etc.

The voltages given are internal calculation values only; you will not be able to actually measure them anywhere on the electronics! Typical values to be expected are:

- Pressure transducers (piston and rod), 500mV @ 0 PSI; 4500mV @ maximum PSI
- Length sensor, 500mV @ retracted boom length; voltage extended depends on the various boom lengths.
- Angle sensor, 4500mV at 0°; 2500mV at 45°; or 500mV at 90°

Please refer to table below for more values:

Voltage Values displayed [mV] +/- 10mV	Value displayed	Value
Pressure Transducers		
300 bar, type 314		
	<i>PSI</i>	<i>Bar</i>
500	0	0
1500	1088	75
2500	2176	150
3500	3263	225
4500	4351	300

Angle Sensor	<i>degrees</i>	
500	90	boom vertical
1500	67.5	
2500	45	
3500	22.5	
4500	0	boom horizontal

Length Sensor	<i>feet</i>	
500	0	fully retracted
1500		
2500		
3500		
4500		

If the displayed value does differ from the actual value, please refer to the following sections to find the cause of the problem:

If the displayed angle is incorrect, please go to section [Angle Sensing](#).

If the displayed length is incorrect, please go to section [Length Sensing](#)

If the displayed pressures are incorrect, please go to section [Pressure Sensing](#)

SLEW POT SIGNALS:

Reference Angle	Sig 1 (mA) ±0.03mA	Sig 2 (mA) ±0.03mA
0°	4.00	12.00
45°	8.00	16.00
90°	12.00	20.00
135°	16.00	16.00
180°	20.00	12.00
-135°	16.00	8.00
-90°	12.00	4.00
-45°	8.00	8.00

If the displayed angle is incorrect, please go to section [Slewing Sensing](#)

14 DRAWINGS

14.1 Components of the LMI system PAT iFLEX2 with iSCOUT expert compact

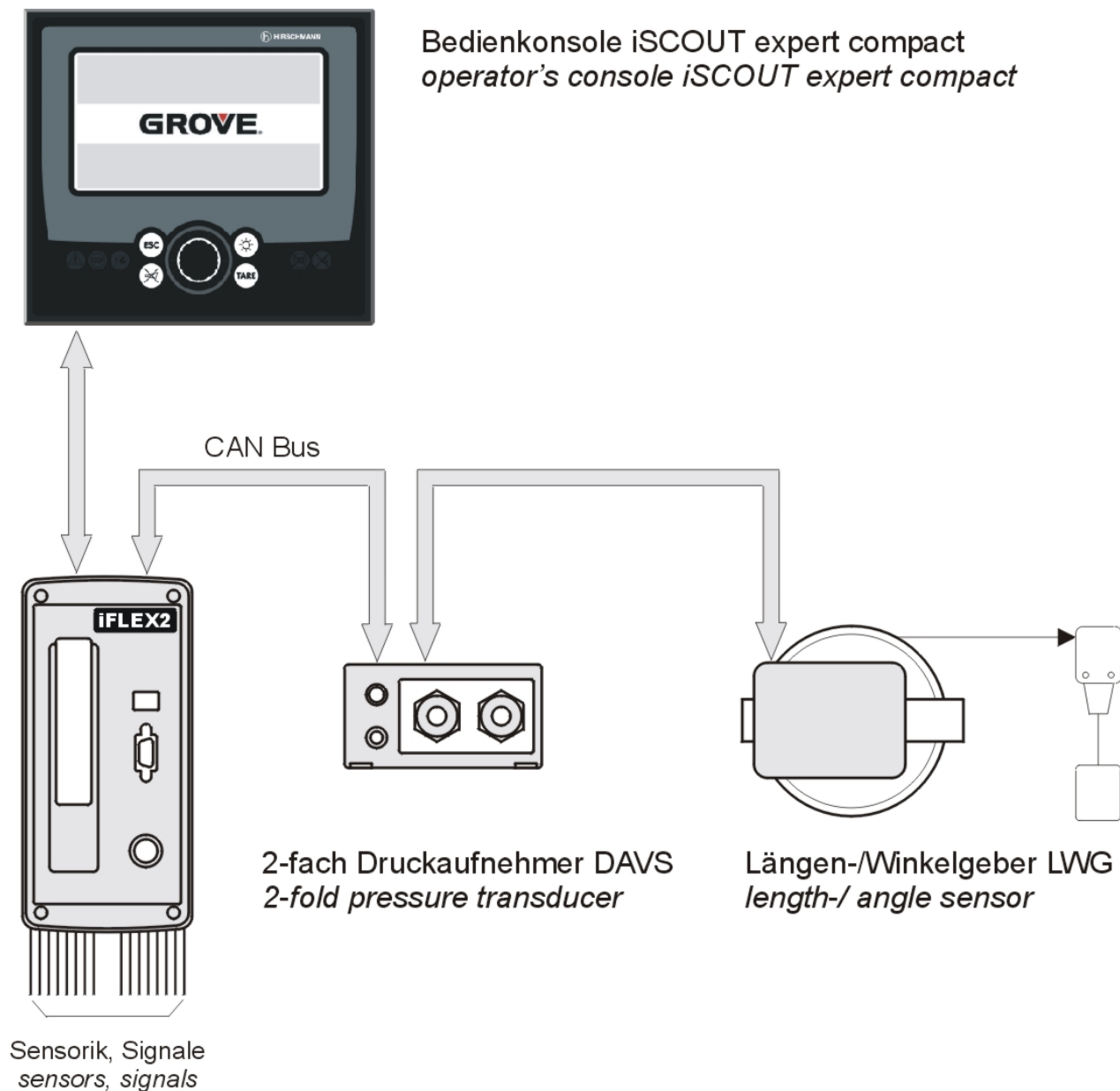

14.2 BLOCK DIAGRAM

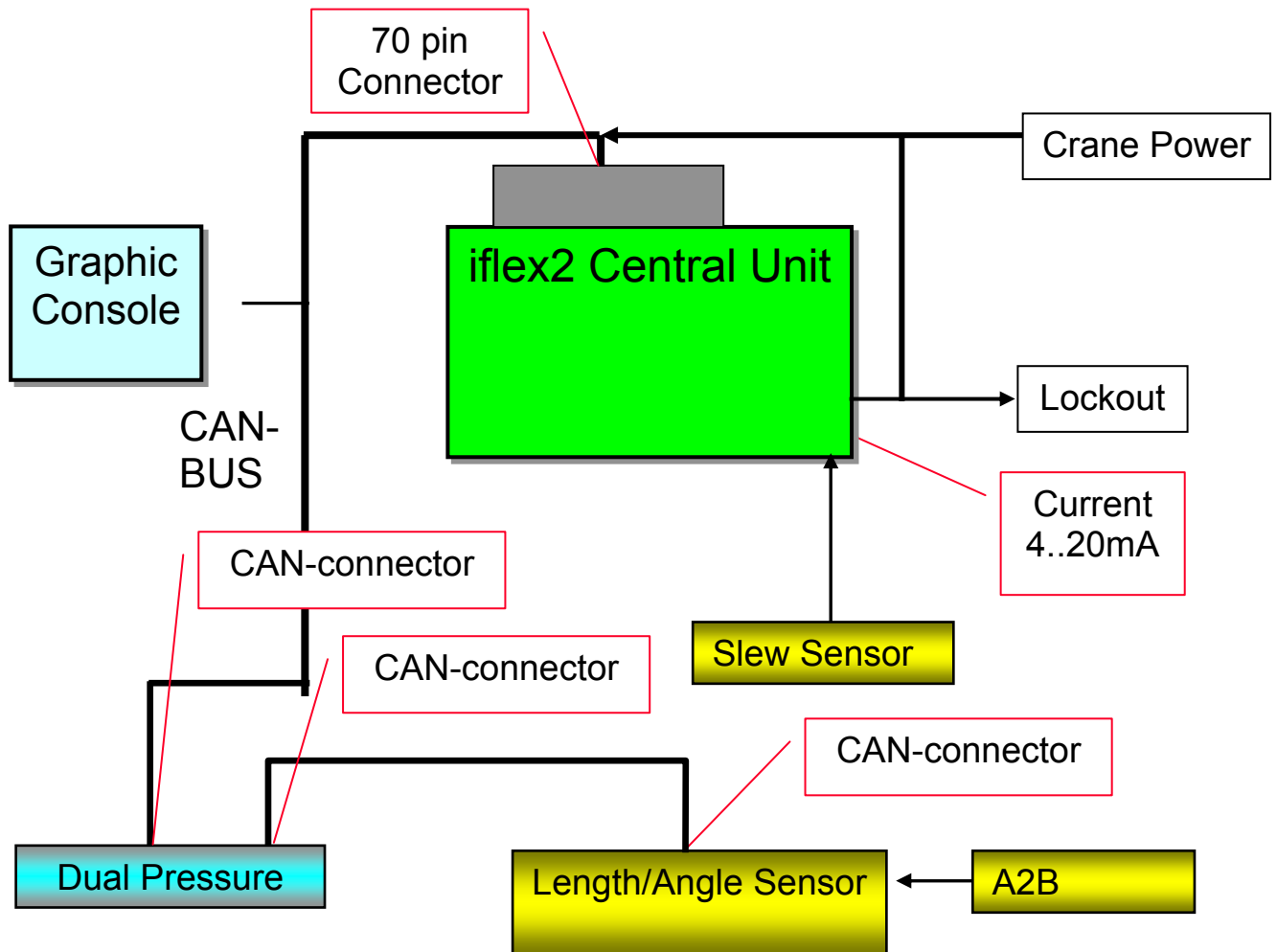

14.3 ELECTRICAL SYSTEM DIAGRAM STANDARD SYSTEM

14.3.1 Central Unit, Overview

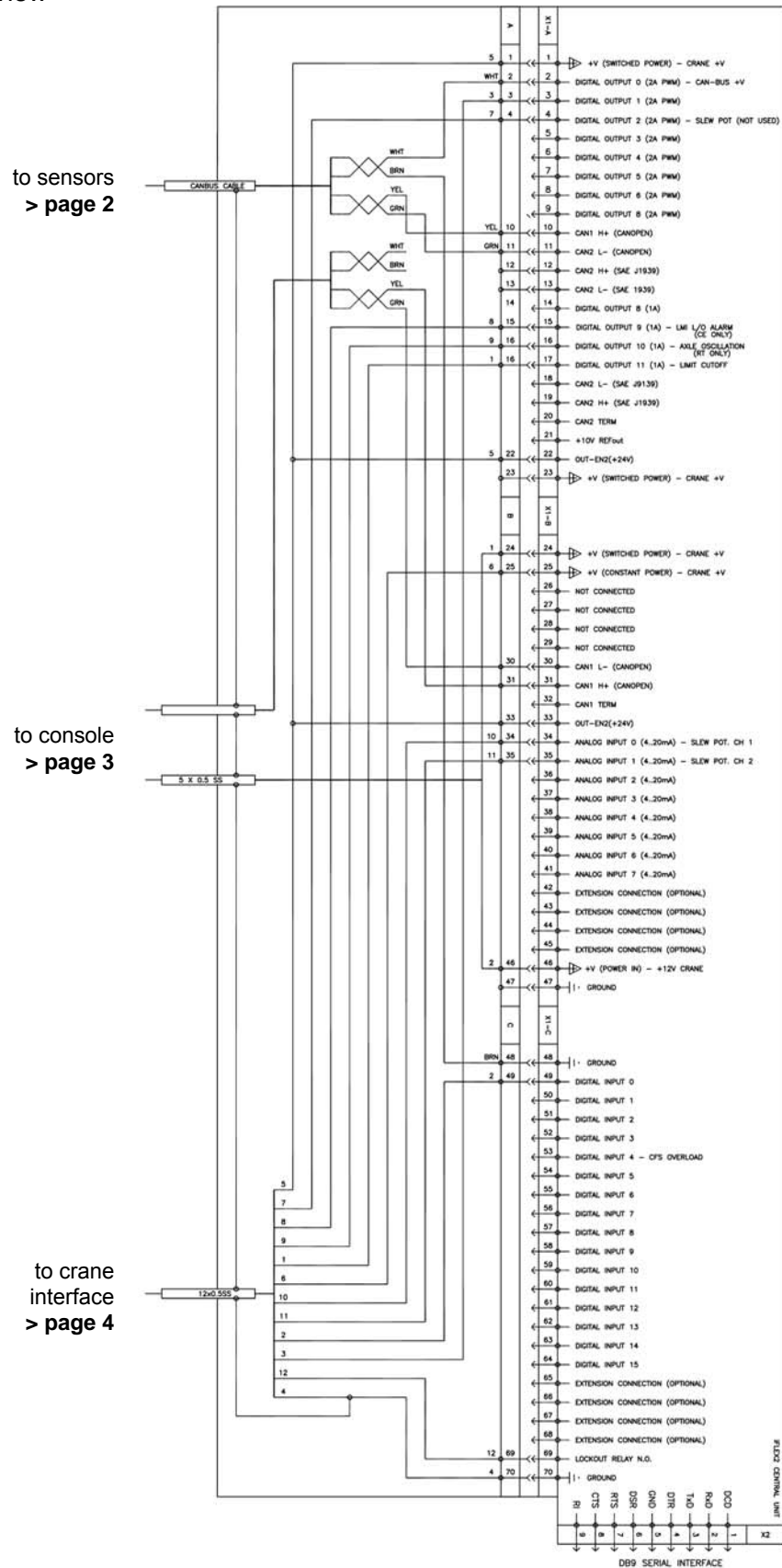

Hirschmann Automation and Control GmbH reserves proprietary rights to this drawing and to the data shown there on. The drawing and data are confidential and are not to be used or reproduced without the written consent of Hirschmann. This drawing is subject to technical modification without prior notice.

14.3.2 Central Unit, Detail A

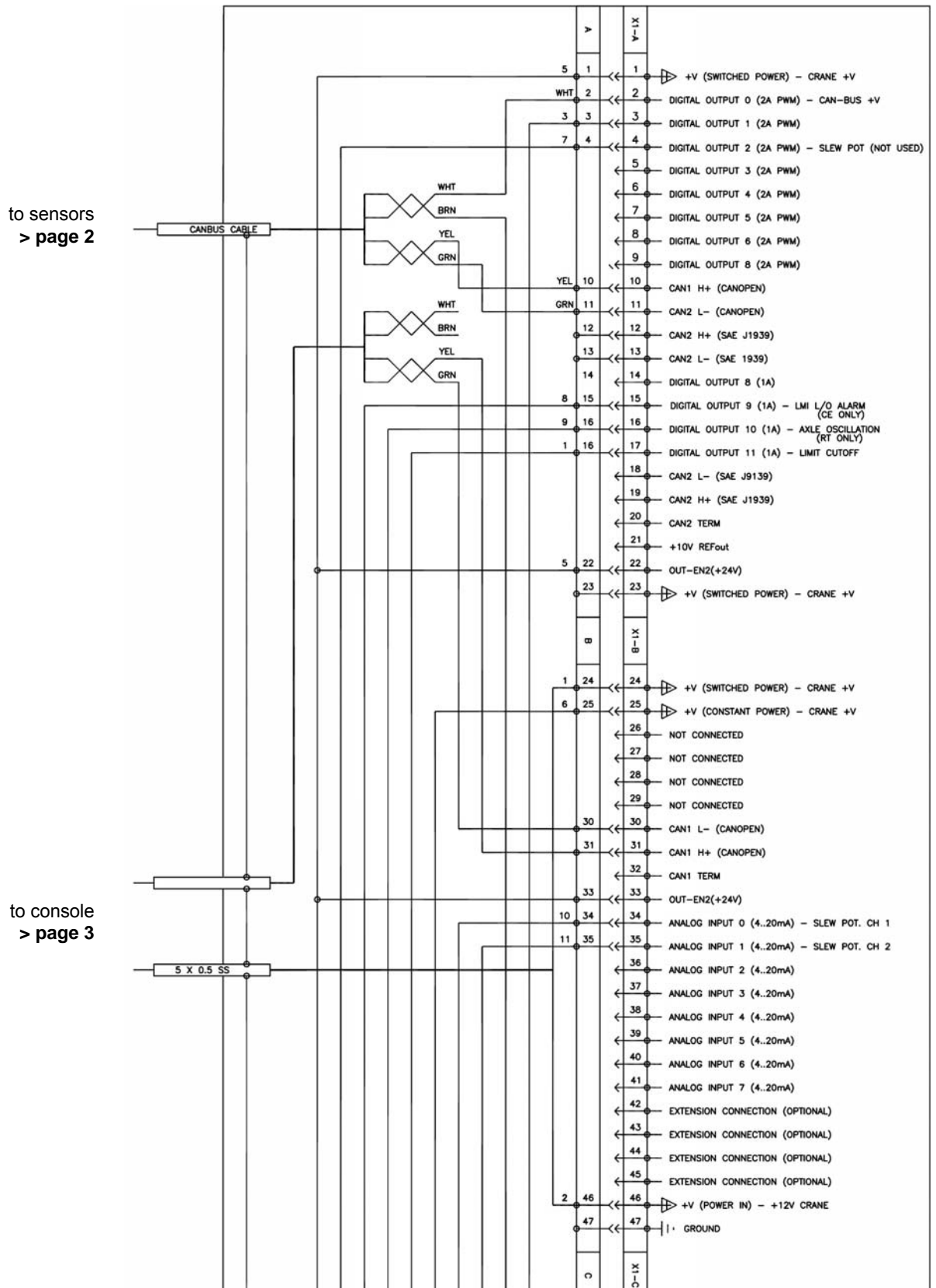

Hirschmann Automation and Control GmbH reserves proprietary rights to this drawing and to the data shown there on. The drawing and data are confidential and are not to be used or reproduced without the written consent of Hirschmann. This drawing is subject to technical modification without prior notice.

14.3.3 Central Unit, Detail B

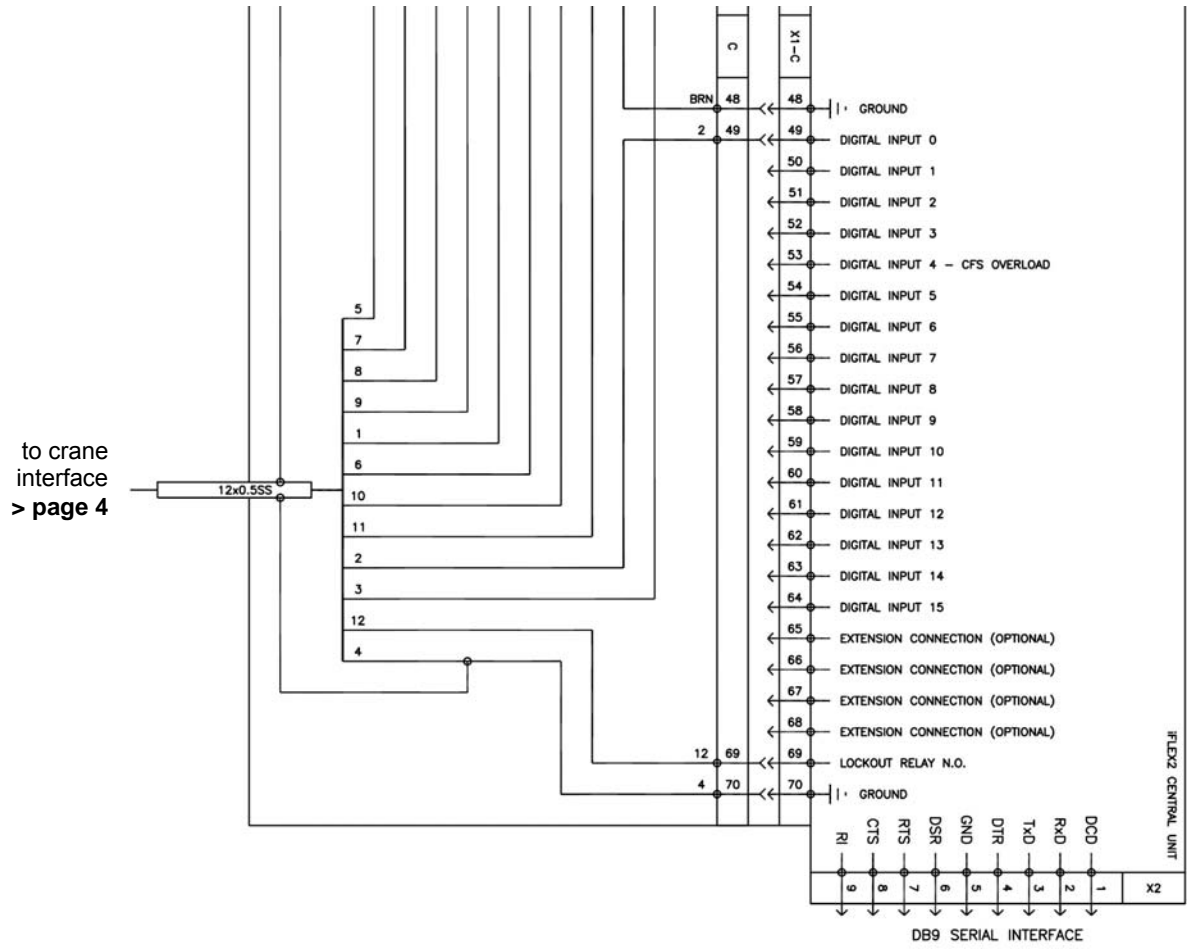

to crane interface
> page 4

Hirschmann Automation and Control GmbH reserves proprietary rights to this drawing and to the data shown there on. The drawing and data are confidential and are not to be used or reproduced without the written consent of Hirschmann. This drawing is subject to technical modification without prior notice.

14.3.4 Sensors Wiring (page 2)

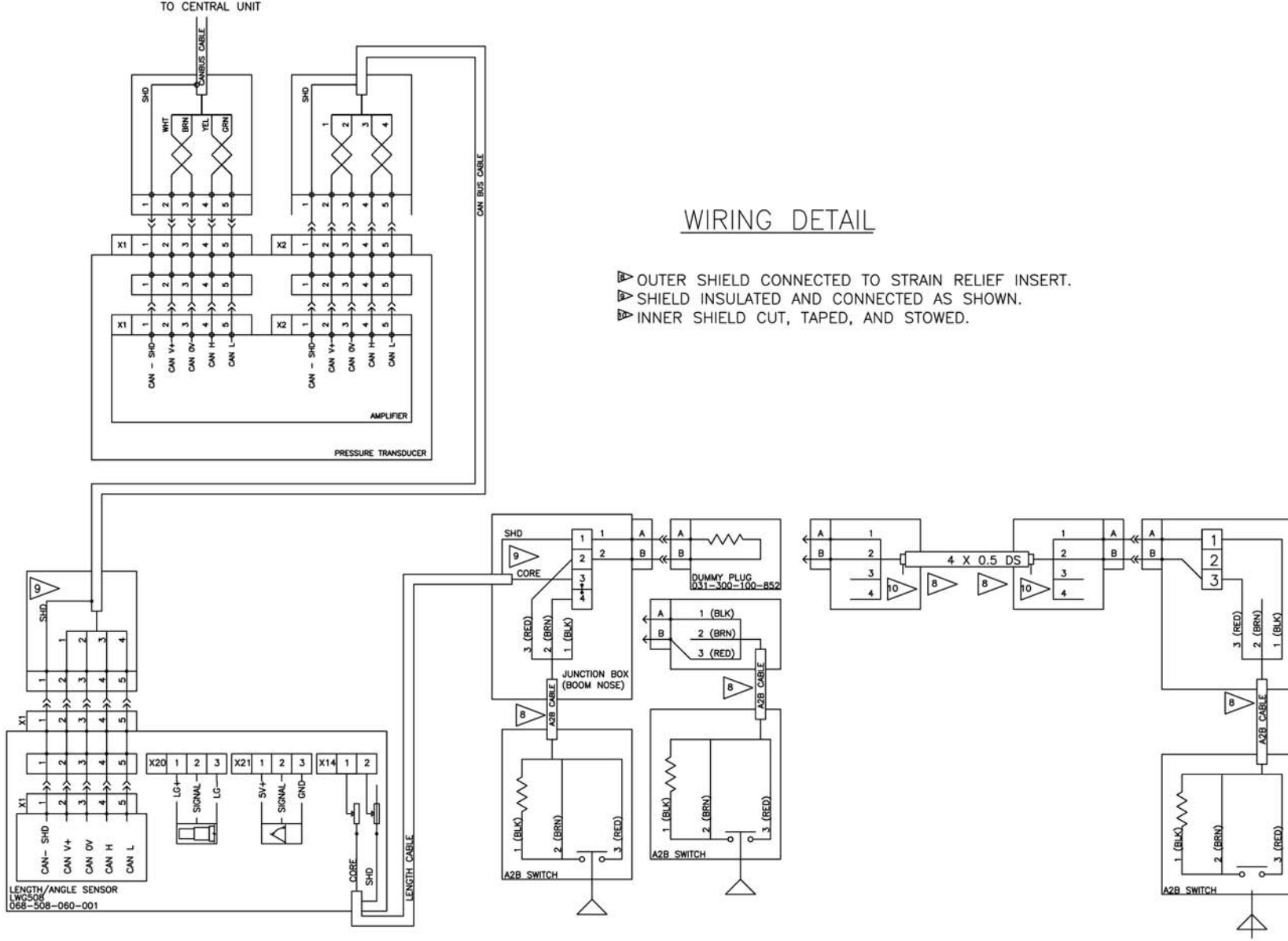

Hirschmann Automation and Control GmbH reserves proprietary rights to this drawing and to the data shown there on. The drawing and data are confidential and are not to be used or reproduced without the written consent of Hirschmann. This drawing is subject to technical modification without prior notice.

14.3.5 Console Wiring (page 3)

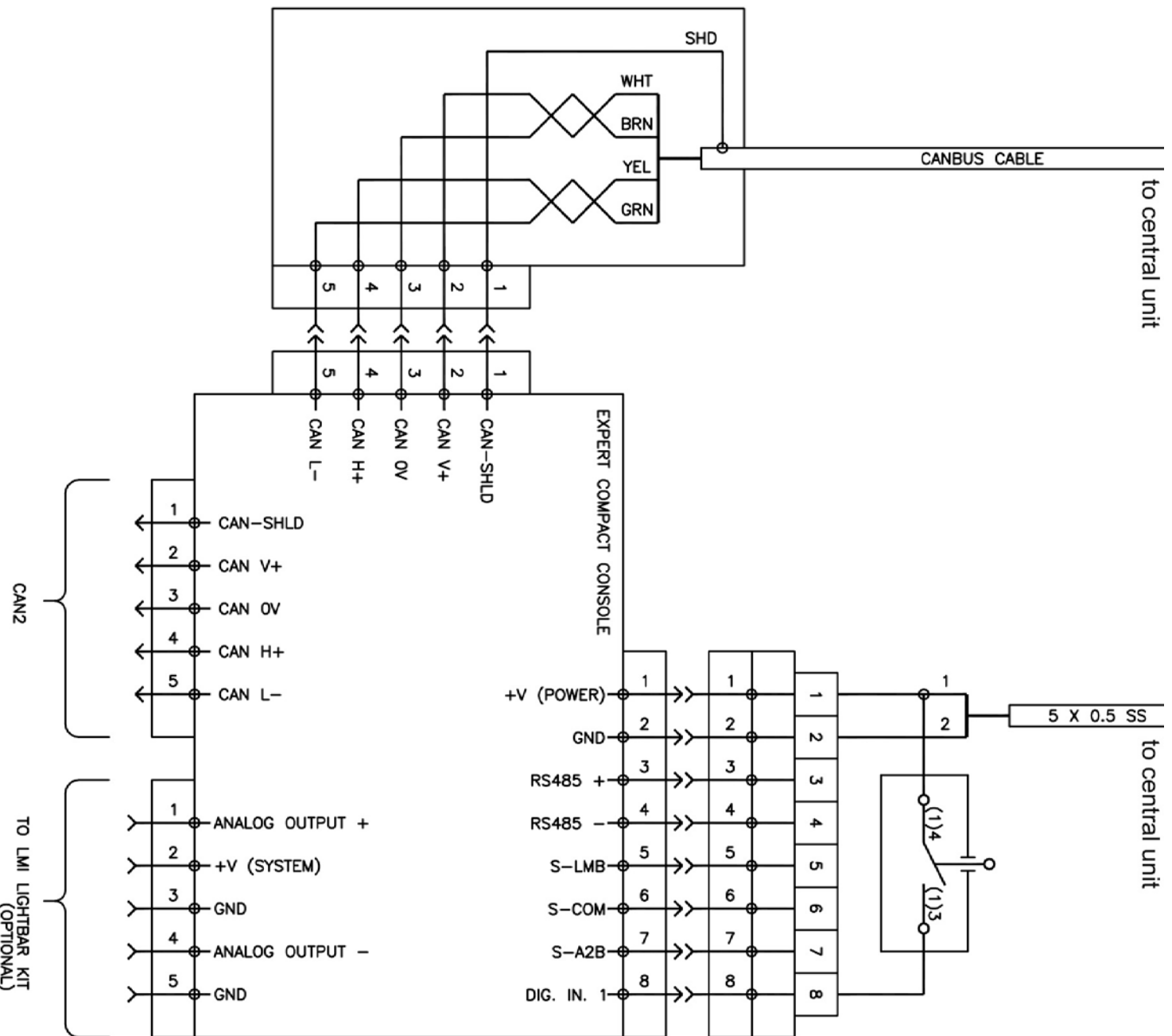

Hirschmann Automation and Control GmbH reserves proprietary rights to this drawing and to the data shown there on. The drawing and data are confidential and are not to be used or reproduced without the written consent of Hirschmann. This drawing is subject to technical modification without prior notice.

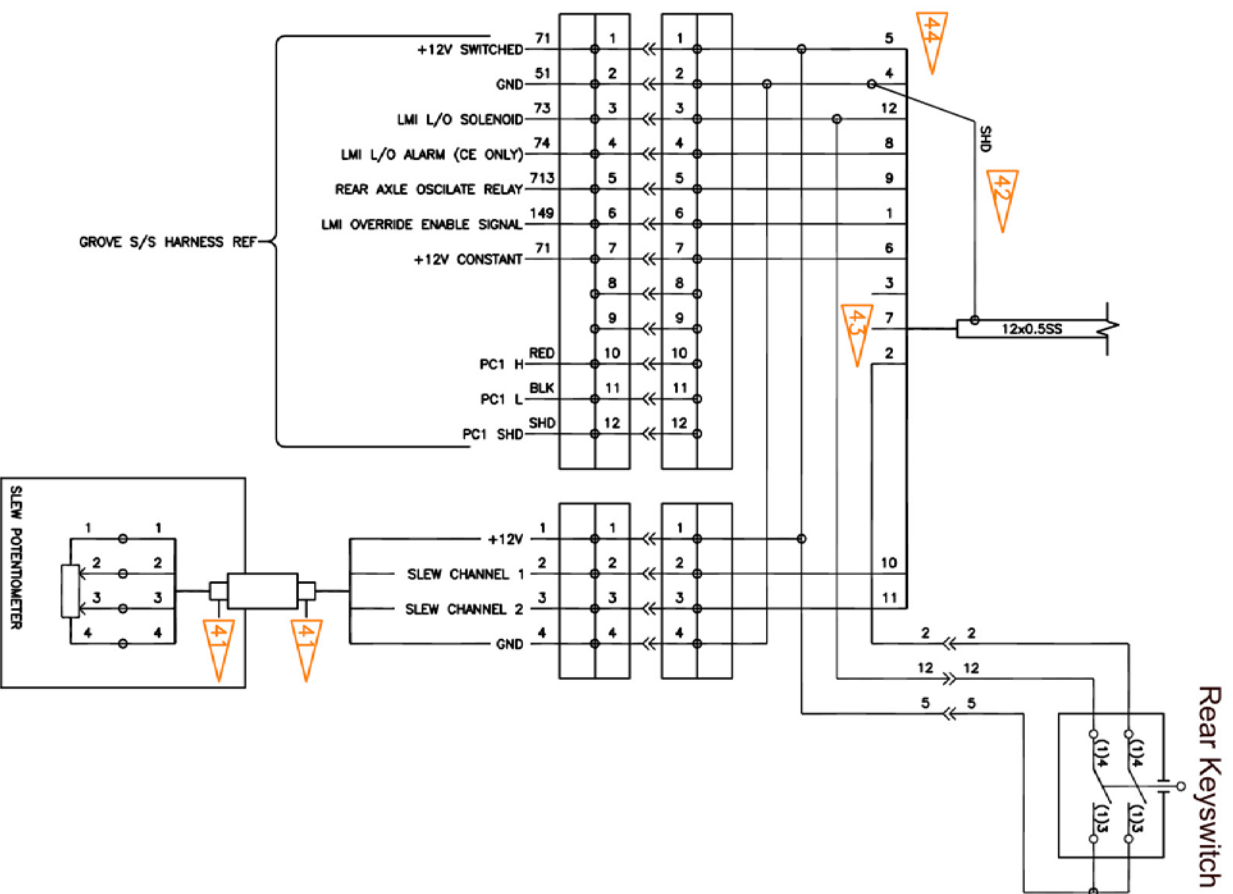

Hirschmann Automation and Control GmbH reserves proprietary rights to this drawing and to the data shown there on. The drawing and data are confidential and are not to be used or reproduced without the written consent of Hirschmann. This drawing is subject to technical modification without prior notice.

14.3.7 Crane Interface RT600E / RT700E / RT875E (page 4)

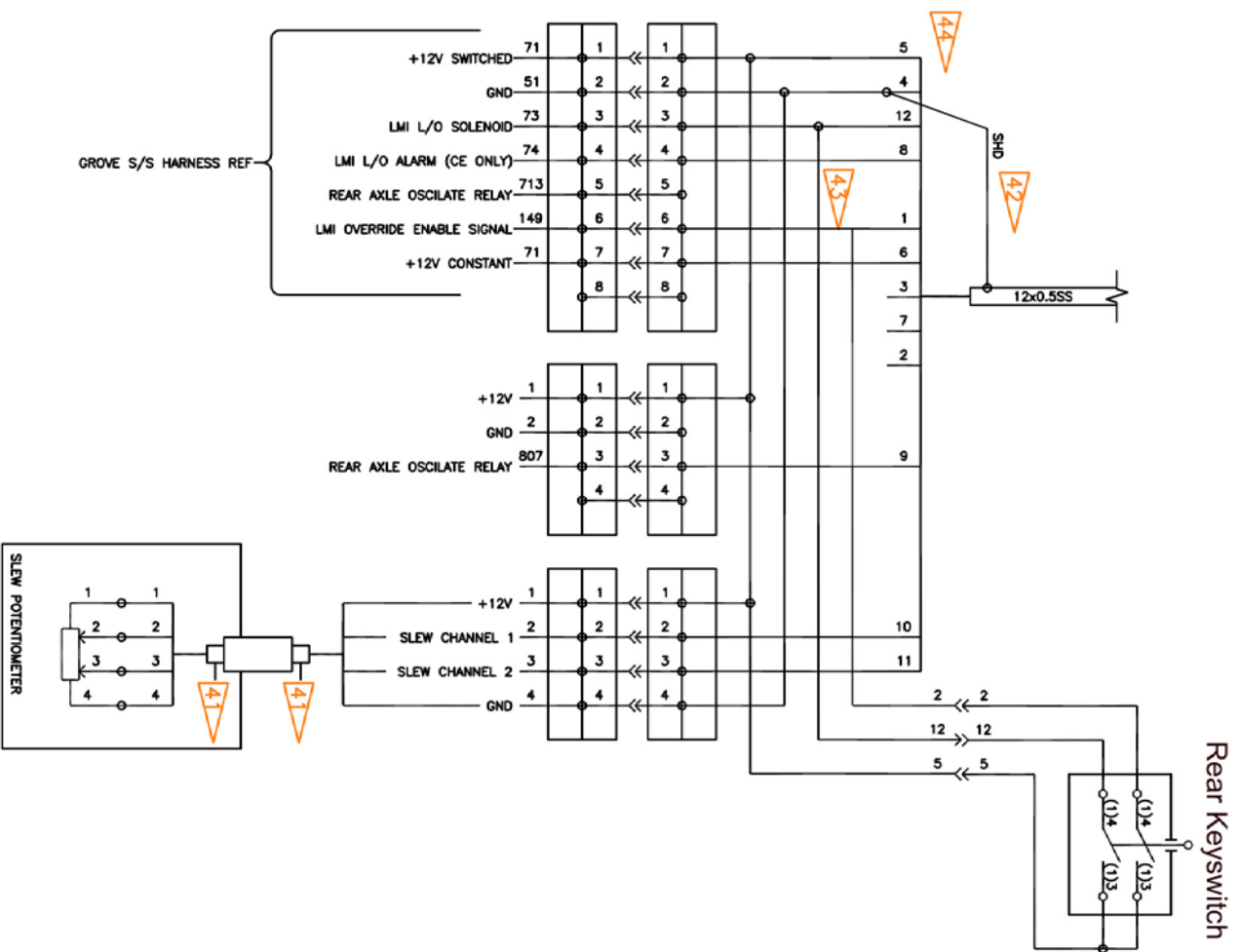

Hirschmann Automation and Control GmbH reserves proprietary rights to this drawing and to the data shown there on. The drawing and data are confidential and are not to be used or reproduced without the written consent of Hirschmann. This drawing is subject to technical modification without prior notice.

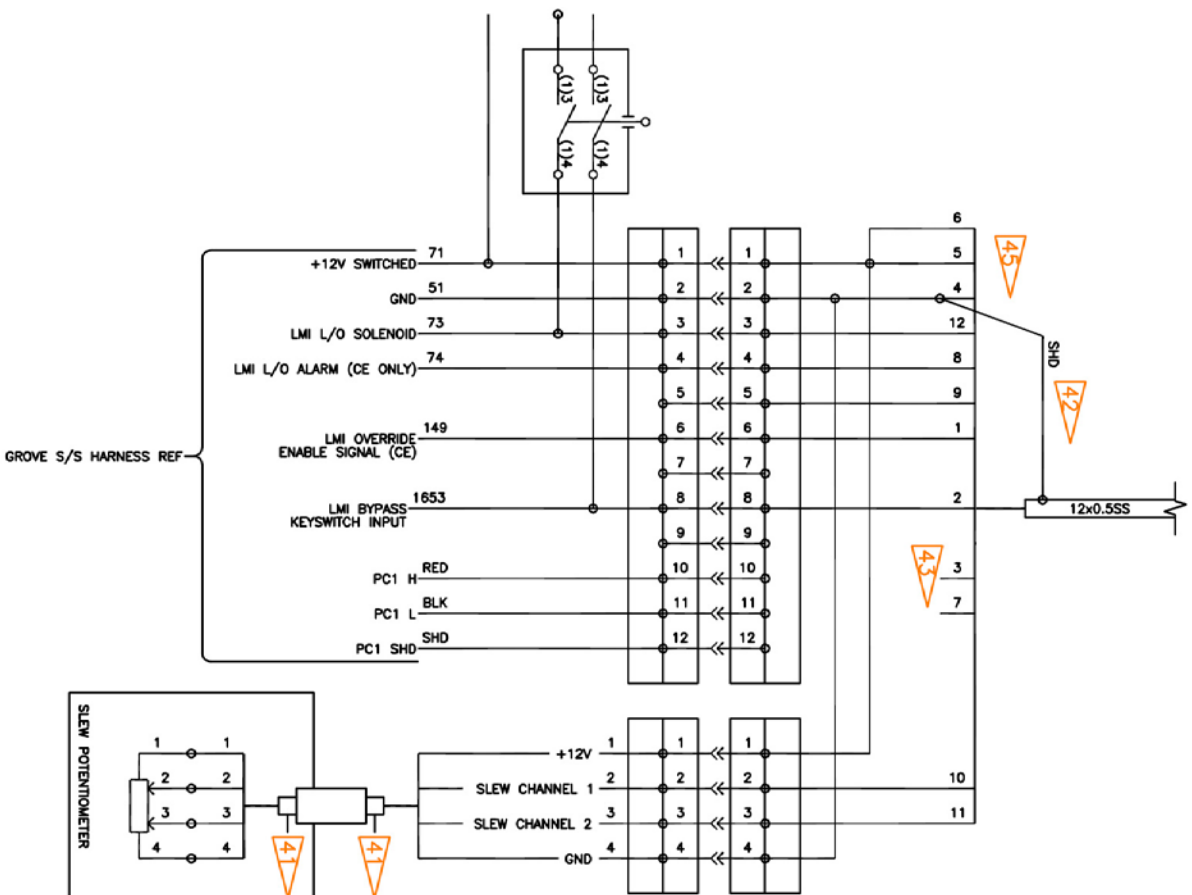

Hirschmann Automation and Control GmbH reserves proprietary rights to this drawing and to the data shown there on. The drawing and data are confidential and are not to be used or reproduced without the written consent of Hirschmann. This drawing is subject to technical modification without prior notice.

14.4 MAIN CENTRAL UNIT CONNECTOR

This is a 70 pass connector

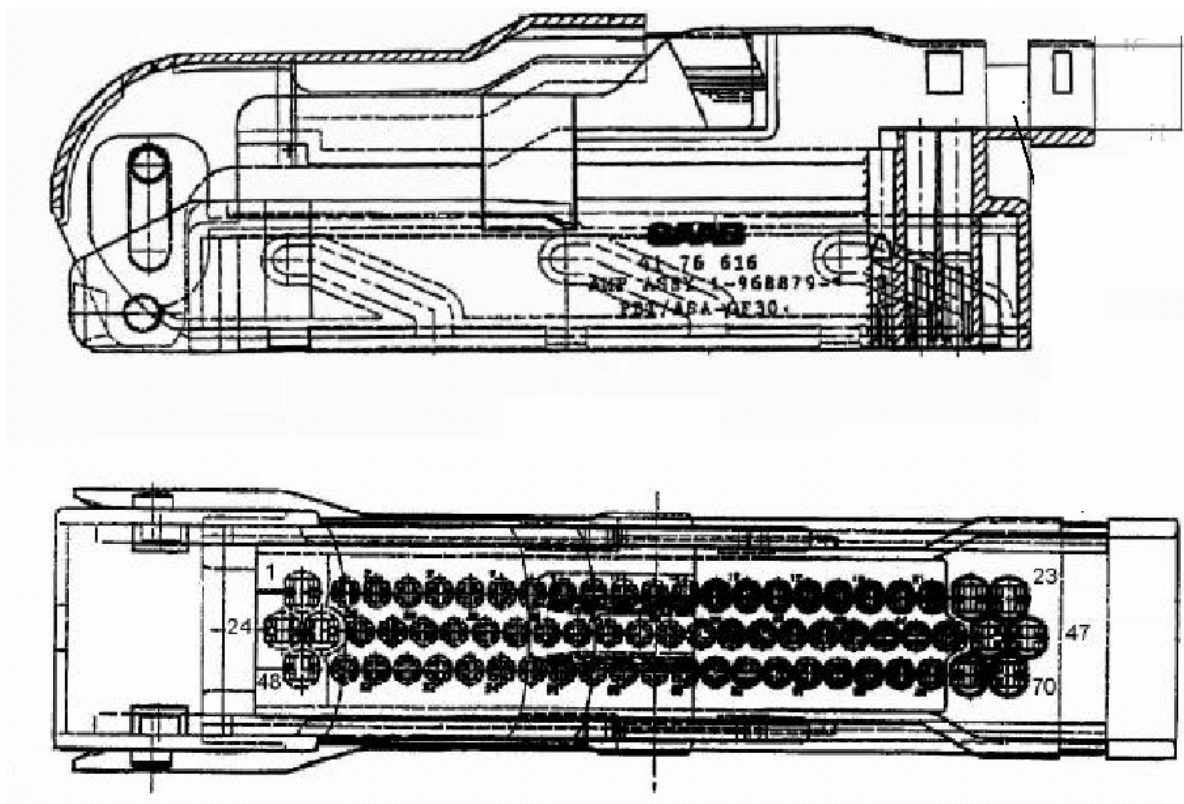

14.4.1 Cable Reel (LG152/0056) Wiring Diagram

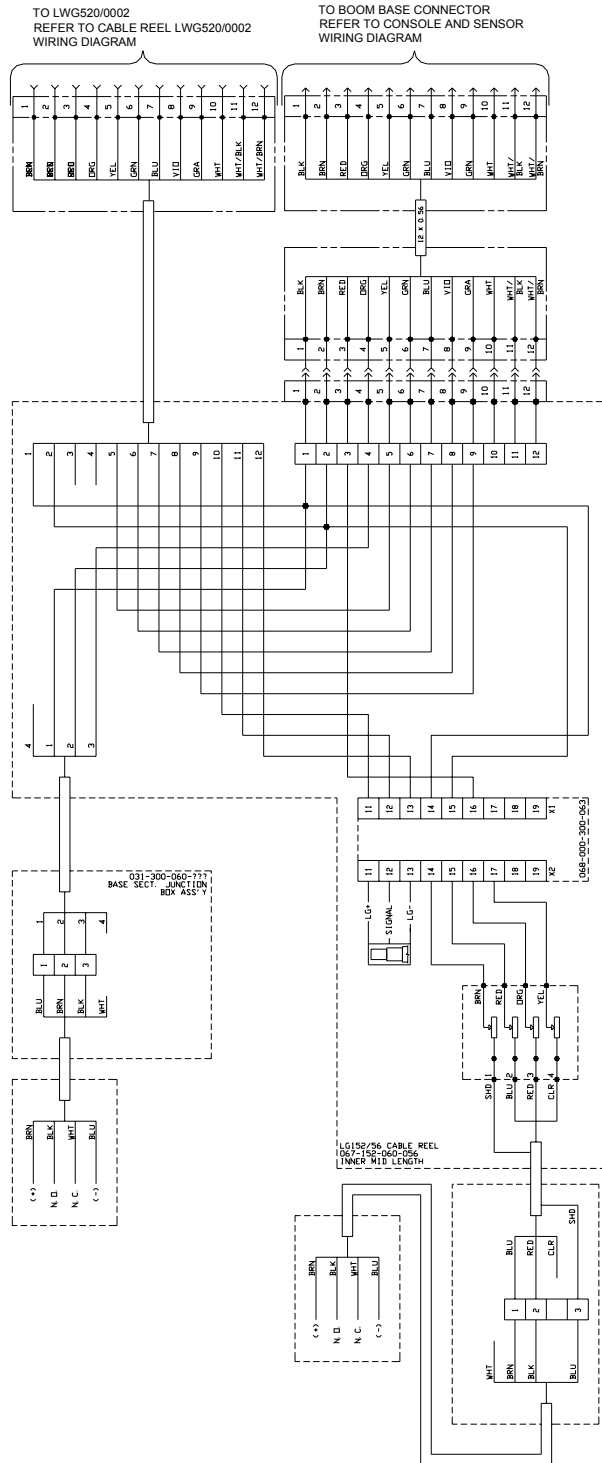

Hirschmann Automation and Control GmbH reserves proprietary rights to this drawing and to the data shown there on. The drawing and data are confidential and are not to be used or reproduced without the written consent of Hirschmann. This drawing is subject to technical modification without prior notice.

14.4.2 Cable Reel (LWG520/0002) Wiring Diagram

TO PRESSURE TRANSDUCER BLOCK
REFER TO CONSOLE AND SENSOR
WIRING DIAGRAM

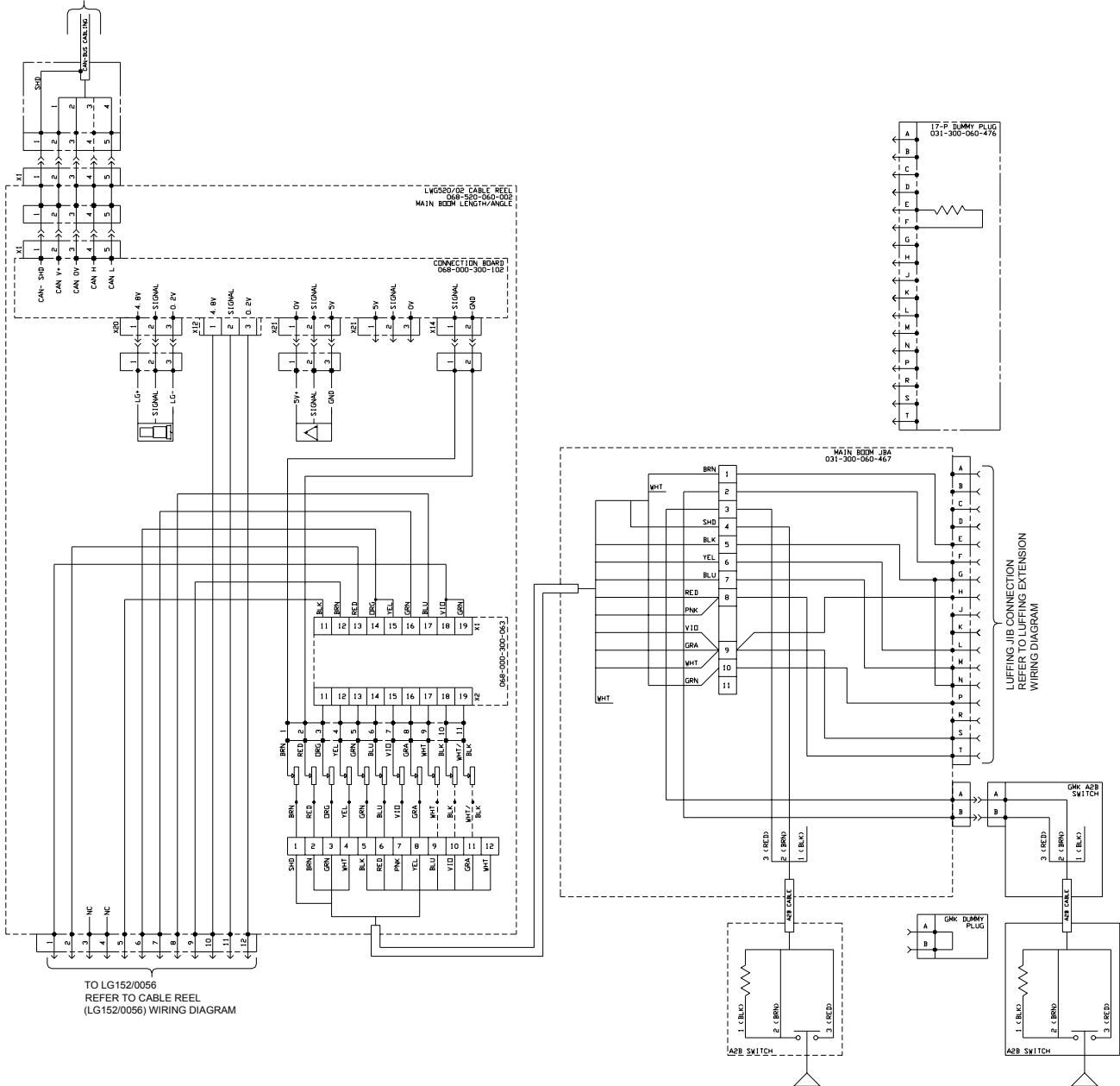

Hirschmann Automation and Control GmbH reserves proprietary rights to this drawing and to the data shown there on. The drawing and data are confidential and are not to be used or reproduced without the written consent of Hirschmann. This drawing is subject to technical modification without prior notice.

14.4.3 Luffer Extension Wiring Diagram

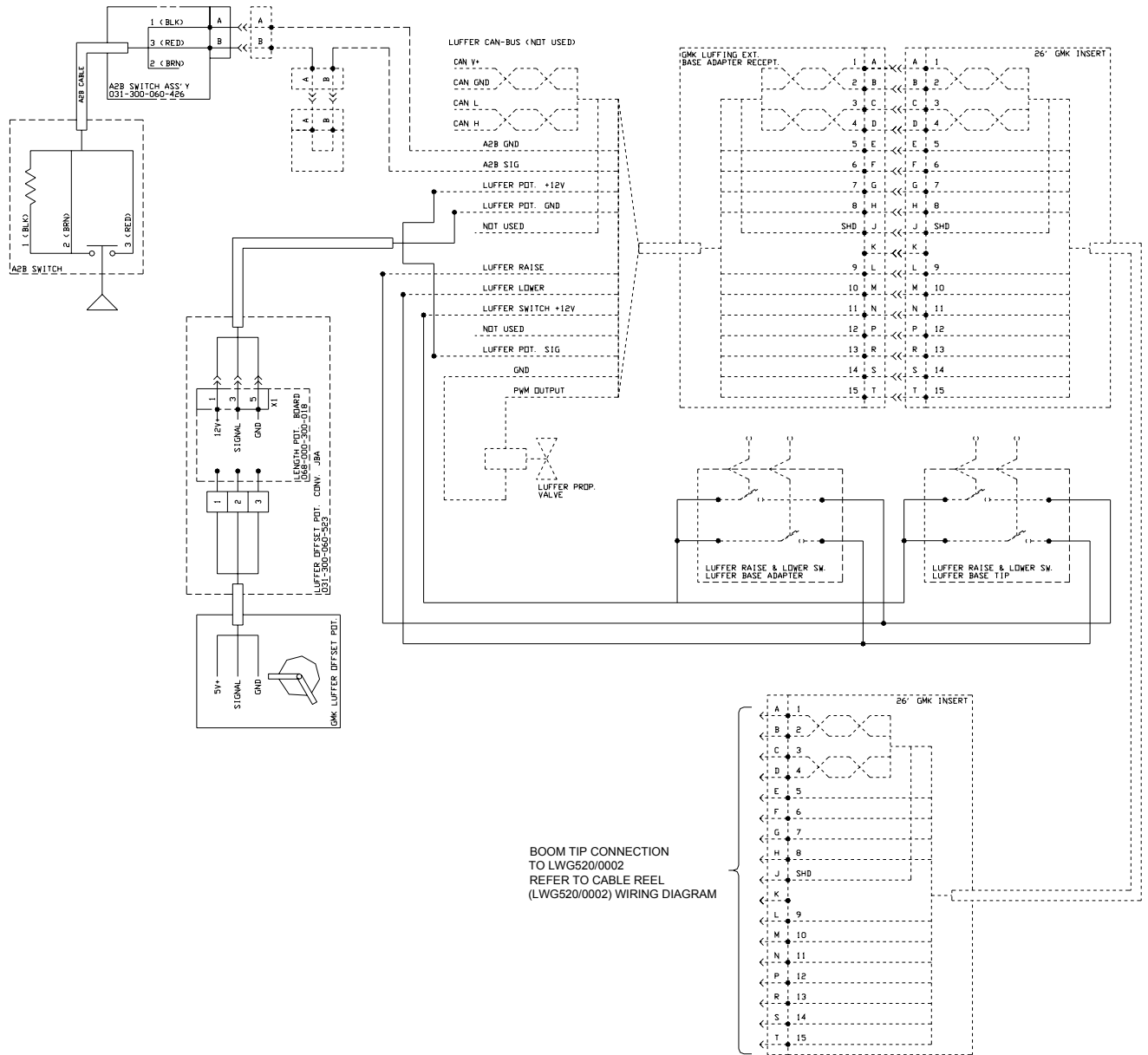

Hirschmann Automation and Control GmbH reserves proprietary rights to this drawing and to the data shown there on. The drawing and data are confidential and are not to be used or reproduced without the written consent of Hirschmann. This drawing is subject to technical modification without prior notice.

15 SENSOR CALIBRATION

15.1 ACTIVATING THE SERVICE SCREEN FOR SENSOR CALIBRATION

- to access the service screen and sensor calibration function (from main menu):

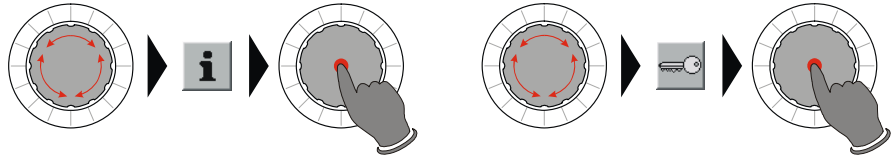

▼ input service code (for access to calibration menus)

	<p>For access to the calibration menus it is necessary to input a matching 5-digit code.</p> <p>Use the rotary selection wheel to input a numeral, and then push the wheel button to select the next digit.</p> <p>If input is complete the confirmation screen appears:</p>
--	--

▼ input service code (confirmation screen)

	<p>OK, confirm selected code</p> <p>Cancel and return to LMI screen</p>
--	---

Now you can follow the calibration procedure step by step or can select the type of calibration by scrolling with function key . Press "ESC" to finish calibration procedure.

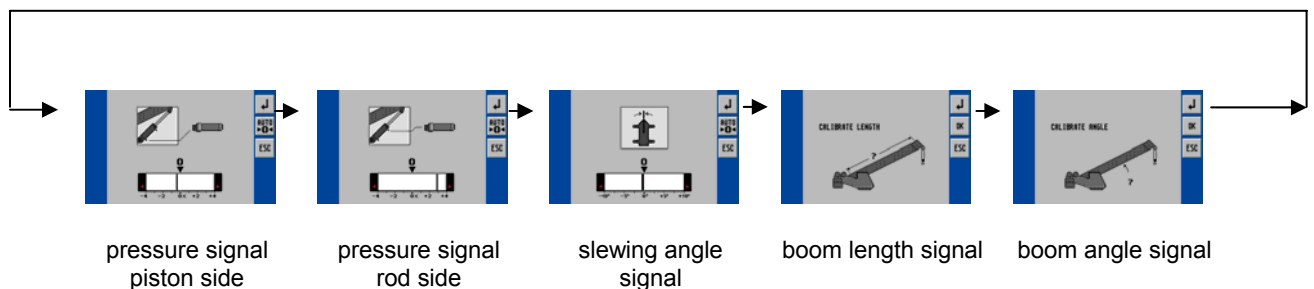

15.2 ZERO-SETTING THE PRESSURE INPUTS

NOTE: The only thing adjustable for the pressure transducers is the zero point, which is the signal the transducer outputs when there is no (zero) pressure sensed.



Ensure there is no pressure in the hydraulic line when disconnecting the hoses from pressure transducers!

The display shows which transducer (piston-side, rod-side or force) is being zeroed and a horizontal dial marks the present pressure (or force) difference in %.

NOTE: there are two calibration screens: for piston and for rod transducer.

NOTE: The range for auto-calibrating this value is from -4% to +4%. By pressing the “AUTO” key, the zero setting occurs automatically and the indicator line will move to zero on the dial.

▼ Calibration screen (pressure transducer piston side)

	↵	skip calibration step
	AUTO ▶0◀	auto-calibrate (set to zero)
	ESC	cancel and return to LMI screen

▼ Calibration screen (pressure transducer rod side)

	↵	skip calibration step
	AUTO ▶0◀	auto-calibrate (set to zero)
	ESC	cancel and return to LMI screen

15.3 ZERO-SETTING THE SLEWING INPUTS

NOTE: The only thing adjustable for the slew potentiometer is the zero point, which is complete when the boom is at the 0° position over the front of the crane.

NOTE: The range for auto-calibrating this value is from -10° to +10°. By pressing the “AUTO” key, the zero setting occurs automatically and the indicator line will move to zero on the dial.

▼ Calibration screen (slewing angle)

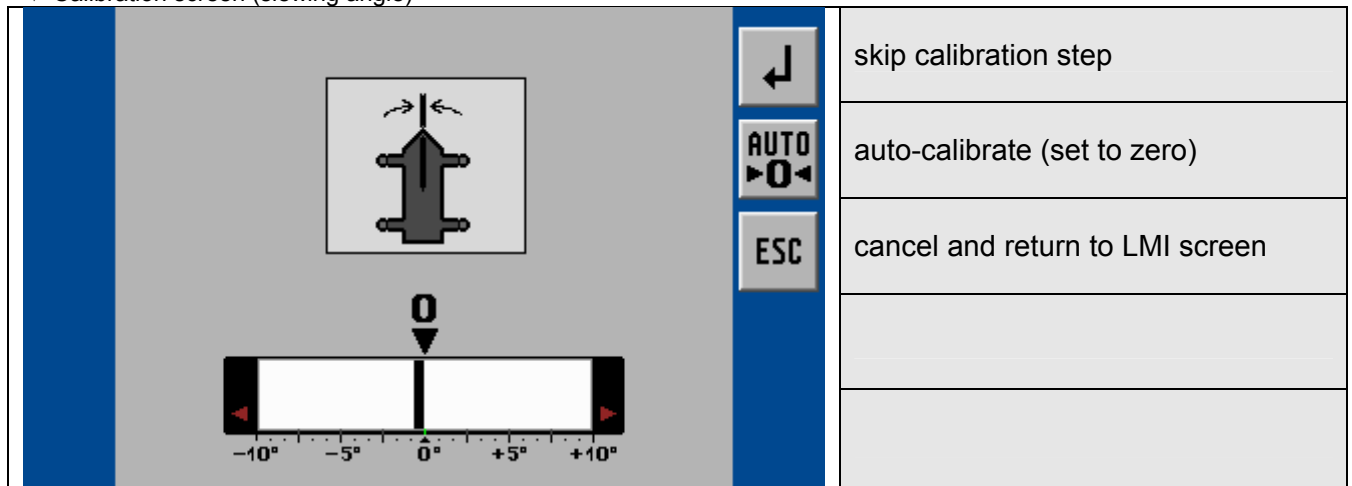





15.4 LENGTH SENSOR CALIBRATION PROCEDURE

NOTE: The length sensor can be calibrated for its zero point and its full range.

With retracted boom, the potentiometer of the length sensor has to be at its 0 position, which is all the way counter-clockwise. For extended boom, the adjustment is done by software as described below.

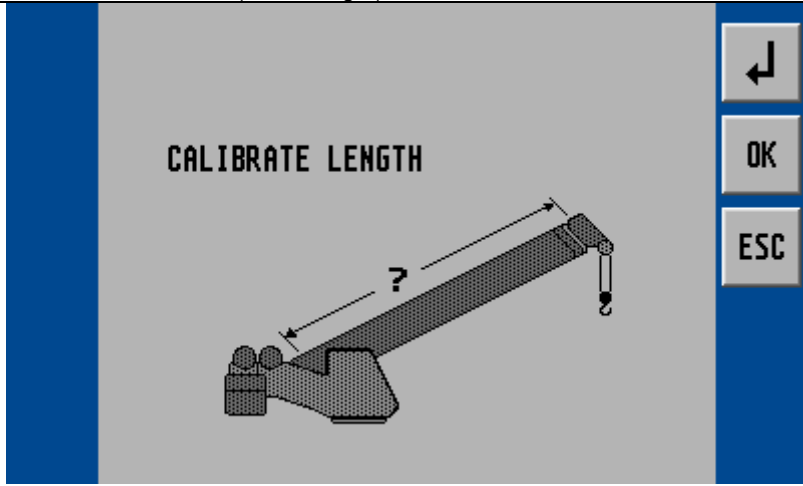

The length should be calibrated to be about 0.1 feet (or 0.05m for metric) accurate for retracted and extended lengths. Perform the following steps:

▼ Calibration screen (boom length)

		skip calibration step
		start length calibration
		cancel and return to LMI screen

Start procedure by pressing "OK"

▼ Start calibration minimum length

		next calibration step
		cancel and return to LMI screen



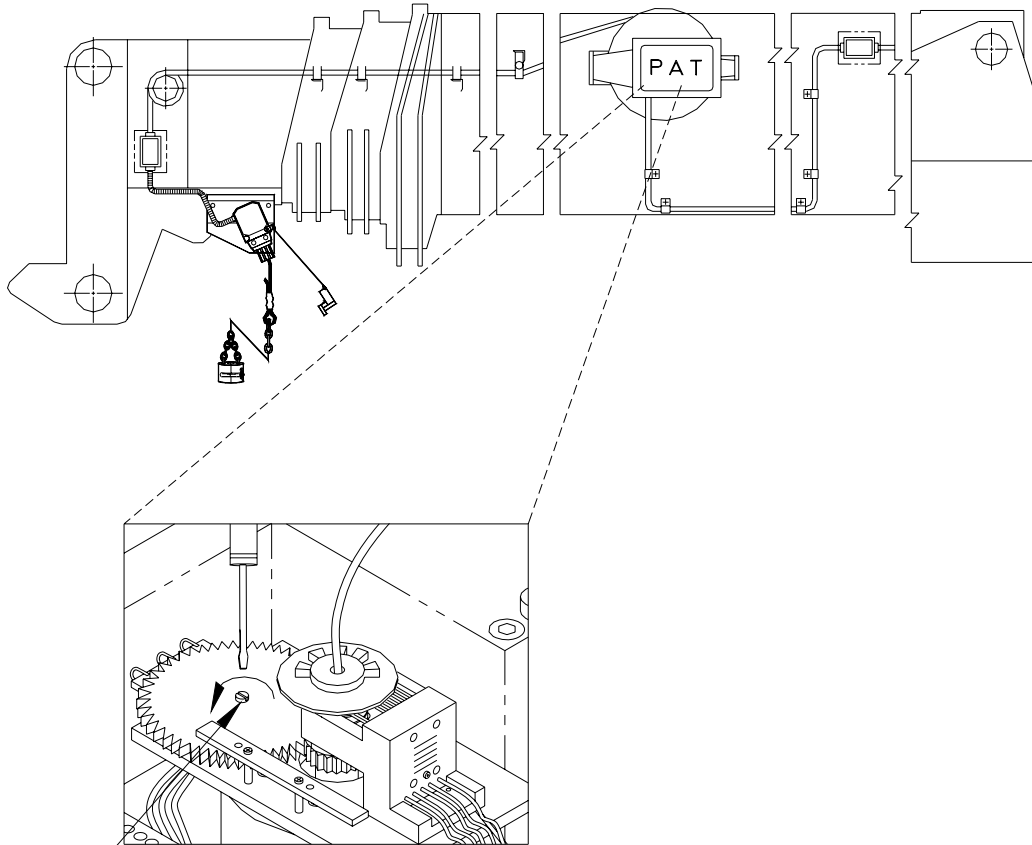

- Fully retract the main boom and check if indicated length is within 0.1 feet (or 0.05m for metric) of actual retracted boom length.
- If it is not, adjust length potentiometer mechanically as described below:



ADJUST LENGTH POTENTIOMETER, WITH BOOM FULLY RETRACTED
TURN THE CENTER SCREW COUNTER CLOCKWISE TO A SOFT STOP.

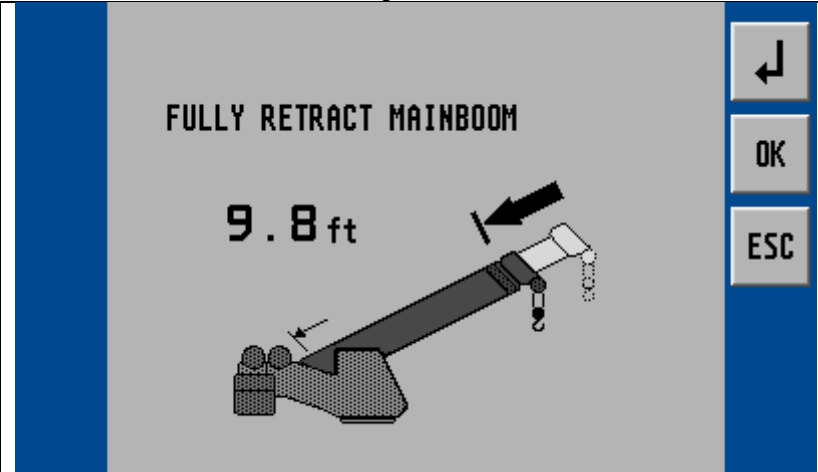

- With boom fully retracted turn the center screw of the length pot unit counter clockwise to a soft stop.
- During adjustment an additional button "OK" appears. Check value and set actual length as fully retracted length by pressing OK. Afterward next calibration screen appears.

▼ Calibration screen minimum length

		skip calibration step
		set minimum length
		cancel and return to LMI screen



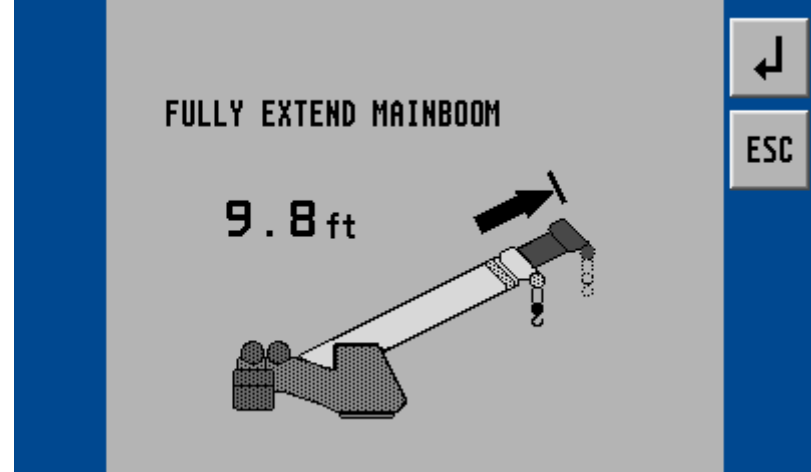

- Now extend main boom all the way out. Make sure you are within the allowed operating range (especially maximum radius).
- During telescoping out the boom an additional button "OK" appears.

▼ Start calibration maximum length

	 skip calibration step
	 cancel and return to LMI screen

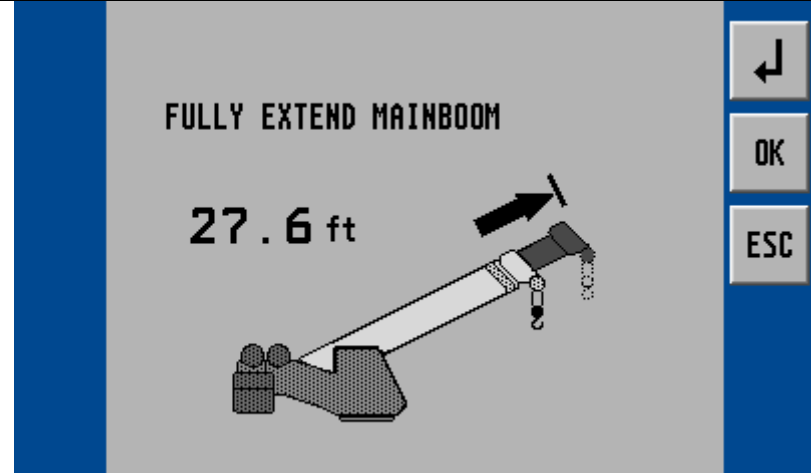
- Check whether boom is fully extended, then press "OK". Afterward next calibration step (angle) appears.

▼ Calibration screen maximum length

	 skip calibration step
	 set maximum length
	 cancel and return to LMI screen

15.4.1 Cable Reel Length Cable Replacement Procedure

Replace length cable using the following procedure:
Refer to system electrical wiring diagram and cable reel - parts list

1. Cut old cable at cable drum.
2. Disconnect damaged length cable from junction box at the boom nose.
3. Open cable reel cover and disconnect bus connector.
4. Remove cable reel from mounting brackets.
5. Remove damaged length cable, which is mounted to the slip rings in the cable reel, from slip ring terminal.
6. On the backside of the cable reel, open the strain relief attached to the axle in the center of the drum. Pull existing length cable out of the cable reel.
7. Pull new length cable through the hole, pipe and strain relief and push it through the axle of the reeling drum. Tighten new strain relief to ensure sealing.
8. Reconnect the length cable to the slip ring.
9. Remount cable reel to the boom.
10. Turn reeling drum clockwise to spool the new cable neatly onto the drum.
11. Set pre-load on cable reel by turning the drum counter-clockwise 5 to 8 turns.
12. Run the new length cable through the cable guides and wrap the length cable around the boom tip anchor pin (4 or 5 wraps) and secure with tie wraps. Leave enough length cable to connect into the boom tip junction box.
13. Connect the length cable into the boom tip junction box.
14. Reset length potentiometer in length angle transducer (screw is located in center of white gear); with boom fully retracted, turn potentiometer carefully counter-clockwise until it stops. Recheck length and angle display.
15. Connect bus connector
16. Follow [Length Sensor Adjustment Procedure](#).





15.5 ANGLE SENSOR CALIBRATION PROCEDURE

The angle sensor can be calibrated for its zero point and with steep boom



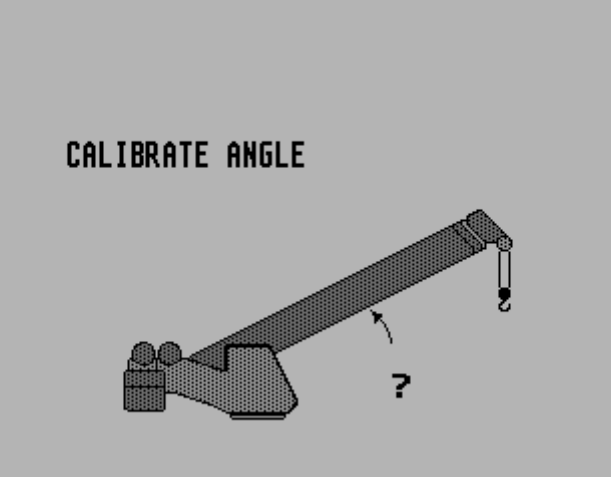

Material required: calibrated inclinometer

- Select Angle sensor calibration menu and start procedure by pressing "OK"

▼ Calibration screen (boom angle)

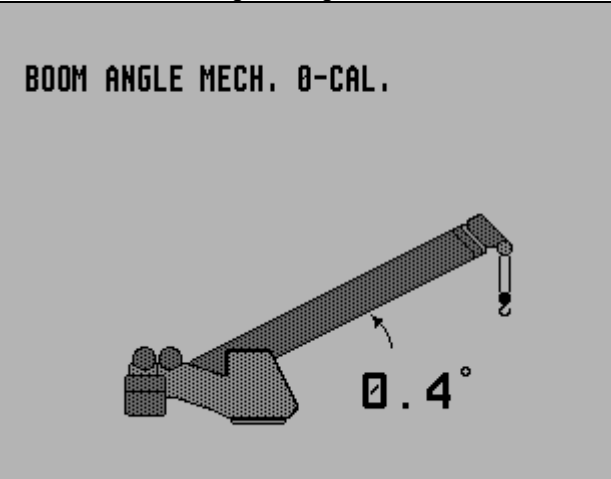
 <p>CALIBRATE ANGLE</p>		skip calibration step
		start angle calibration procedure
		cancel and return to LMI screen





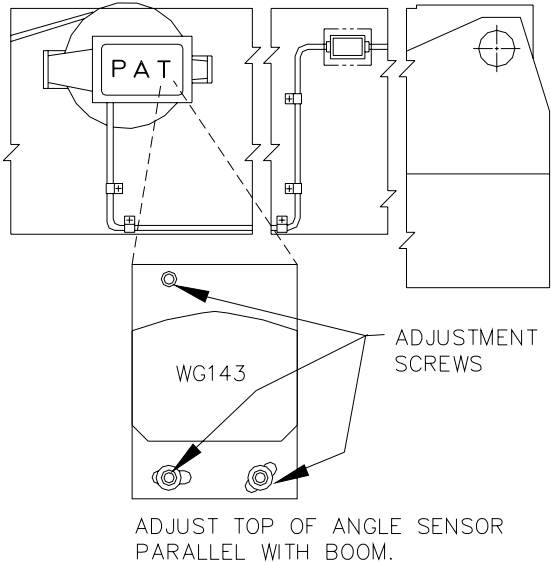



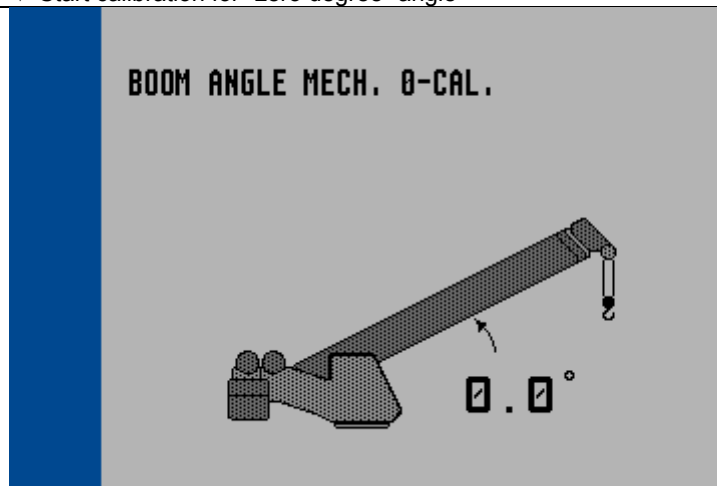

▼ Start calibration for "zero degree" angle

 <p>BOOM ANGLE MECH. 0-CAL.</p>		skip calibration step
		calibrate next angle
		cancel and return to LMI screen

	<p>Boom down.</p> <p>Release adjustment screws of the angle sensor.</p> <p>Mechanically adjust top of angle sensor housing exact parallel with boom by help of inclinometer.</p> <p>Fix adjustment screws of the angle sensor.</p>
---	--







Having adjusted the angle sensor mechanically check value and press "OK" for the next step.

▼ Start calibration for "zero degree" angle

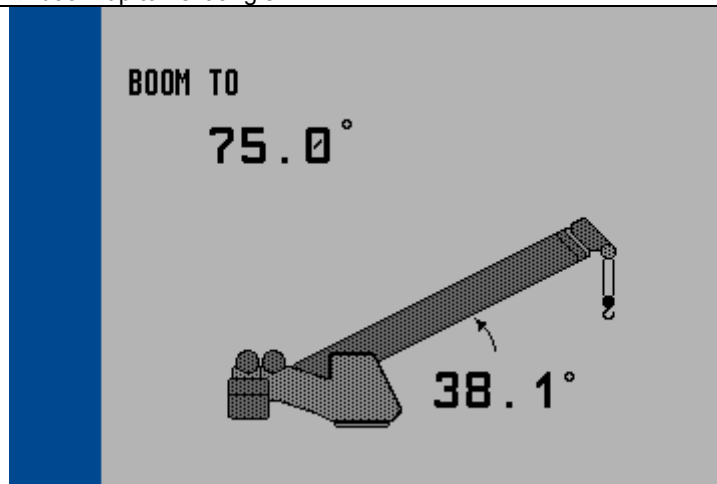
<p>BOOM ANGLE MECH. 0-CAL.</p> 	<table border="1"> <tr> <td></td> <td>skip calibration step</td> </tr> <tr> <td></td> <td>calibrate next angle</td> </tr> <tr> <td></td> <td>cancel and return to LMI screen</td> </tr> <tr> <td></td> <td></td> </tr> <tr> <td></td> <td></td> </tr> </table>		skip calibration step		calibrate next angle		cancel and return to LMI screen				
	skip calibration step										
	calibrate next angle										
	cancel and return to LMI screen										

- Now boom up to steep boom, (range is 70° - 80°)

▼ boom up to next angle

<p>BOOM TO 75.0°</p> 	<table border="1"> <tr> <td></td> <td>skip calibration step</td> </tr> <tr> <td></td> <td></td> </tr> <tr> <td></td> <td>cancel and return to LMI screen</td> </tr> <tr> <td></td> <td></td> </tr> <tr> <td></td> <td></td> </tr> </table>		skip calibration step				cancel and return to LMI screen				
	skip calibration step										
	cancel and return to LMI screen										

When the boom angle is within the calibration range, the screen will add the 'CHANGE', 'SET' and 'OK' text as shown below:

▼ calibrate angle

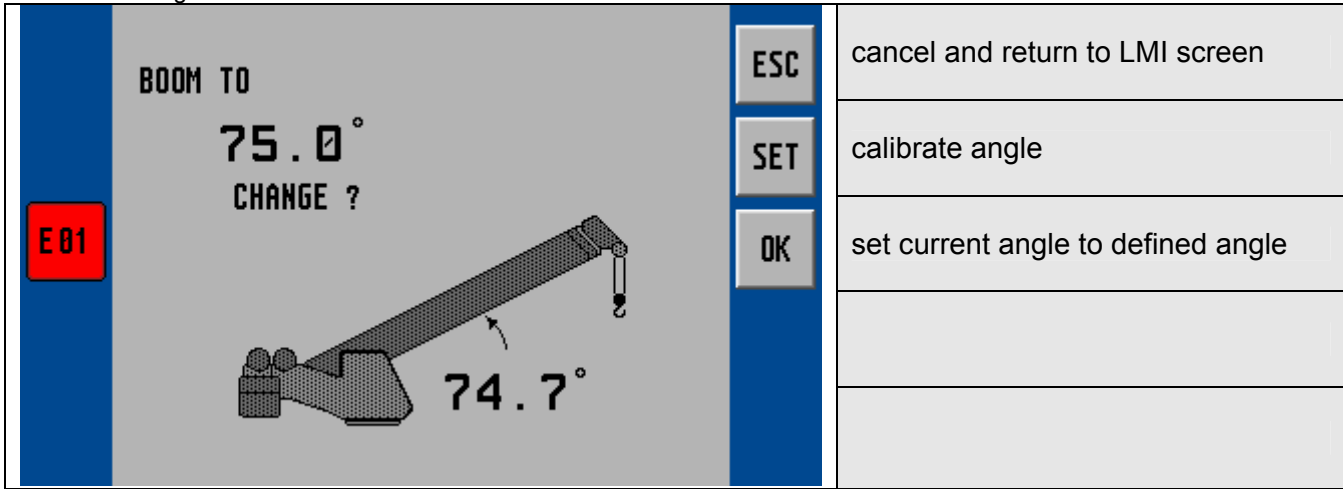

- Measure the boom angle with the inclinometer and when the boom is positioned in the calibration range, compare the measured angle to the displayed angle.
- If the indicated angle is within +/- 0.1 degrees of the measured angle, confirm with 'OK'. Otherwise, select 'SET' to adjust the angle.

▼ adjust angle

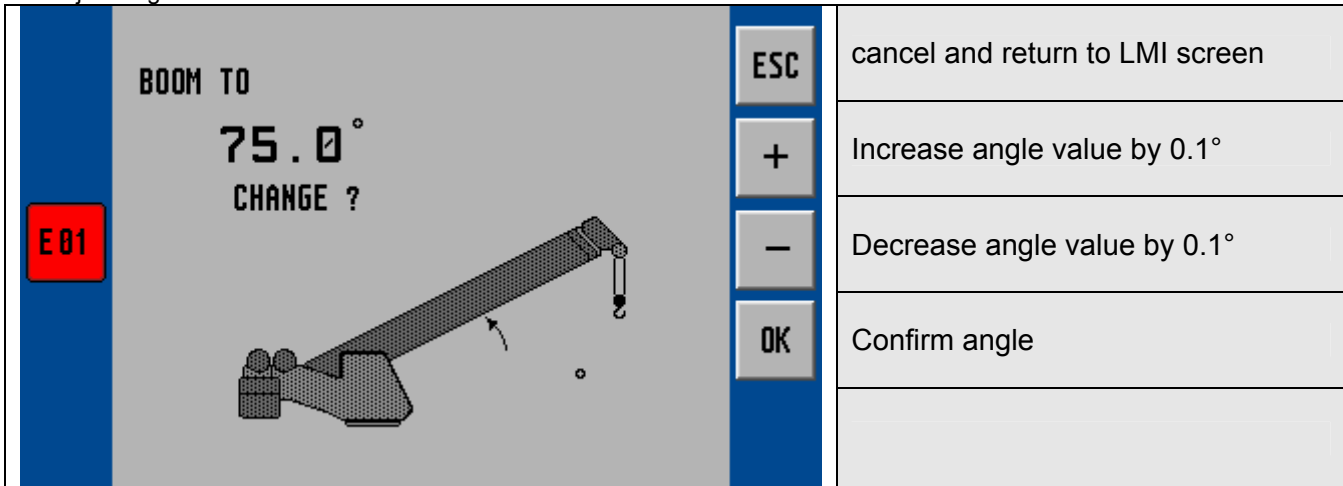

- Once you push 'SET', the screen is going to change to the angle adjustment screen. Use the '+' and '-' buttons to adjust the indicated angle to match the measured angle.
- When the display shows the correct angle, press 'OK'.

Press **ESC** to leave sensor adjustments and return to normal LMI screen.

16 ERROR CODES

The following Error Code Table gives a brief description of Error Codes elimination. Refer to the noted sections for detailed Troubleshooting information.

LMI System Error Code Table (LSQG V 1.xx):

Error code	Error	Cause	Elimination
E01	Fallen below radius range or angle range exceeded	<ul style="list-style-type: none"> Fallen below the minimum radius or gone past the maximum angle specified in the respective load chart due to luffing up the boom too far 	<ul style="list-style-type: none"> Luff down the boom to a radius or angle specified in the load chart.
E02	Radius range exceeded or fallen below angle range	<ul style="list-style-type: none"> Gone past the maximum radius or fallen below the minimum angle specified in the respective load chart due to luffing down the boom too far 	<ul style="list-style-type: none"> Luff up the boom to a radius or angle specified in the load chart.
E03	Non-permitted slewing zone (no load area)	<ul style="list-style-type: none"> The slewing zone with load is not permitted 	<ul style="list-style-type: none"> Slew to permitted area
E04	Operating mode not acknowledged or non permitted slewing zone	<ul style="list-style-type: none"> A non existing operating mode has been selected 	<ul style="list-style-type: none"> Set the correct operating mode for the operating state in question
		<ul style="list-style-type: none"> The boom is in a non-permitted slewing zone 	<ul style="list-style-type: none"> Slew the boom to a permitted area.
E05	Prohibited length range	<ul style="list-style-type: none"> Boom has been extended either too far or not far enough, e.g. if it is prohibited to go beyond a certain maximum boom length or with load curves for jibs where the main boom has to be extended to a certain length 	<ul style="list-style-type: none"> Extend/retract boom to the correct length
		<ul style="list-style-type: none"> Length sensor adjustment has changed, e.g. the cable slid off the length sensor reel. 	<ul style="list-style-type: none"> Retract boom. Check the prestress of the cable reel (cable must be taut). Open the length sensor and carefully turn the length sensor pot counterclockwise until the detent by means of a screw driver
		<ul style="list-style-type: none"> Clutch between length sensor pot and drive is defective 	<ul style="list-style-type: none"> Replace the complete clutch including drive wheel and adjust length sensor pot as described above
E06	Radius range exceeded or fallen below angle range with luffing jib operation	<ul style="list-style-type: none"> Maximum radius as specified in the load chart exceeded or fallen below minimum angle due to luffing down the luffing jib too far 	<ul style="list-style-type: none"> Luff the jib to a radius or angle specified in the load chart.
E11	Fallen below lower limit value for measuring channel "length main boom"	<ul style="list-style-type: none"> Length potentiometer is defective PDB variable for analog value not supported 	<ul style="list-style-type: none"> Replace length potentiometer Setup of correct PDB variable for analog value in DGA6.i.3
		<ul style="list-style-type: none"> Electronic component in the measuring channel is defective 	<ul style="list-style-type: none"> Replace sensor unit
E12	Fallen below the lower limit value in the measuring channel "pressure piston side"	<ul style="list-style-type: none"> Pressure transducer is defective. PDB variable for analog value not supported 	<ul style="list-style-type: none"> Replace pressure transducer Setup of correct PDB variable for analog value in DGA6.i.3

Error code	Error	Cause	Elimination
		<ul style="list-style-type: none"> Electronic component in the measuring channel is defective. 	<ul style="list-style-type: none"> Replace sensor unit
E13	Fallen below lower limit value in the measuring channel "pressure rod side"	<ul style="list-style-type: none"> refer to E12 	<ul style="list-style-type: none"> refer to E12
E14	Fallen below lower limit value in measuring channel "force"	<ul style="list-style-type: none"> Force transducer defective Electronic component in the measuring channel is defective. 	<ul style="list-style-type: none"> Replace force transducer Replace sensor unit
E15	Fallen below lower limit value in measuring channel "angle main boom"	<ul style="list-style-type: none"> Angle potentiometer defective PDB variable for analog value not supported 	<ul style="list-style-type: none"> Replace angle sensor Setup of correct PDB variable for analog value in DGA6.i.3
		<ul style="list-style-type: none"> Electronic component in the measuring channel defective. 	<ul style="list-style-type: none"> Replace sensor unit
E16	Fallen below lower limit value in measuring channel "angle 2"	<ul style="list-style-type: none"> Angle potentiometer defective 	<ul style="list-style-type: none"> Replace angle sensor
		<ul style="list-style-type: none"> Electronic component in the measuring channel defective. 	<ul style="list-style-type: none"> Replace sensor unit
E17	Fallen below lower limit value "length telescope I (+II)"	<ul style="list-style-type: none"> Length potentiometer defective 	<ul style="list-style-type: none"> Replace length sensor.
		<ul style="list-style-type: none"> Electronic component in the measuring channel defective 	<ul style="list-style-type: none"> Replace sensor unit
E18	Front outrigger overloaded	<ul style="list-style-type: none"> Front outrigger overloaded 	<ul style="list-style-type: none">
E1A	Fallen below lower limit value in measuring channel "slewing angle 1". slew below allowed range	<ul style="list-style-type: none"> Cable between the central unit and the slewing angle sensor defective or loose. Water inside the plug of the angle sensor 	<ul style="list-style-type: none"> Check cable as well as plugs, replace, if need be.
		<ul style="list-style-type: none"> 1-cannel slew sensor min. value DGA 11.5.7 <> 0 	<ul style="list-style-type: none"> move to allowed slew range
		<ul style="list-style-type: none"> Slewing angle potentiometer is defective 	<ul style="list-style-type: none"> Replace slewing angle sensor
E1B	Fallen below lower limit value in measuring channel "slewing angle 2"	<ul style="list-style-type: none"> Electronic component in the measuring channel defective 	<ul style="list-style-type: none"> Replace sensor unit
		<ul style="list-style-type: none"> refer to E1A 	<ul style="list-style-type: none"> refer to E1A
E1C	Fallen below lower limit value in measuring channel "luffing jib angle"	<ul style="list-style-type: none"> Angle potentiometer defective 	<ul style="list-style-type: none"> Replace angle sensor
		<ul style="list-style-type: none"> Electronic component in the measuring channel defective. 	<ul style="list-style-type: none"> Replace sensor unit
E21	Upper limit value in measuring channel "main boom length" has been exceeded.	<ul style="list-style-type: none"> refer to E11 	<ul style="list-style-type: none"> refer to E11
E22	Upper limit value in measuring channel "pressure piston side" has been exceeded	<ul style="list-style-type: none"> refer to E12 	<ul style="list-style-type: none"> refer to E12
E23	Upper limit value in measuring channel "pressure rod side" has been exceeded.	<ul style="list-style-type: none"> refer to E12 	<ul style="list-style-type: none"> refer to E12
E24	Upper limit value in measuring channel "force" has been exceeded.	<ul style="list-style-type: none"> refer to E14 	<ul style="list-style-type: none"> refer to E14
E25	Upper limit value in measuring channel "main boom angle" has been exceeded.	<ul style="list-style-type: none"> refer to E15 	<ul style="list-style-type: none"> refer to E15
E26	Upper limit value in measuring channel "angle 2" has been exceeded.	<ul style="list-style-type: none"> refer to E16 	<ul style="list-style-type: none"> refer to E16

Error code	Error	Cause	Elimination
E27	Upper limit value in measuring channel "length telescope I (+II) has been exceeded.	<ul style="list-style-type: none"> refer to E17 	<ul style="list-style-type: none"> refer to E17
E2A	Upper limit value in measuring channel "slewing angle 1" has been exceeded slew above allowed range	<ul style="list-style-type: none"> refer to E1A 1-cannel slew sensor max. value DGA 11.5.8 <> 0 	<ul style="list-style-type: none"> refer to E1A move to allowed slew range
E2B	Upper limit value in measuring channel "slewing angle 2" has been exceeded	<ul style="list-style-type: none"> refer to E1A 	<ul style="list-style-type: none"> refer to E1A
E2C	Upper limit value in measuring channel "luffing jib angle" has been exceeded	<ul style="list-style-type: none"> Angle potentiometer defective Electronic component in the measuring channel defective. 	<ul style="list-style-type: none"> Replace angle sensor Replace sensor unit
E31	Error in the system program	<ul style="list-style-type: none"> The system program file is defective. Flash-EPROM defective 	<ul style="list-style-type: none"> Upload valid system software Replace central unit
E32	Error in the power supply	<ul style="list-style-type: none"> +UB System not present at the system start +UB System not present at the system finish Contact problems at +UB switch off/on 	<ul style="list-style-type: none"> +UB System and +UB Power must be wired separately: +UB System connected direct with the crane battery. +UB Power for switch on/off +UB switch off/on again
E37	Error in the logical program flow	<ul style="list-style-type: none"> System program file is defective Flash-EPROM defective 	<ul style="list-style-type: none"> Upload valid system software Replace central unit
E38	System program and crane data file do not match.	<ul style="list-style-type: none"> The system program in the LMI does not match to the programming in the crane data file 	<ul style="list-style-type: none"> Upload valid system program file or the valid crane data file
E39	System program and load chart file do not match	<ul style="list-style-type: none"> The system program in the LMI and the programming in the load chart file do not match. 	<ul style="list-style-type: none"> Upload valid system program file or the valid load chart file
E43	Error in the write/read memory, (RAM)	<ul style="list-style-type: none"> Write/read memory (RAM) or central unit defective. 	<ul style="list-style-type: none"> Replace central unit
E47	Error in the monitored write/read memory. The CRC verification of the monitored write/read memory provides an incoherent result	<ul style="list-style-type: none"> The CRC sign of the monitored write/read memory is wrong The buffer battery is discharged (< 2V at 1kOhm). Central unit defective. 	<ul style="list-style-type: none"> Restart the LMI Replace buffer battery on the central unit. Replace central unit
E51	Error in the crane data file	<ul style="list-style-type: none"> No valid data in the crane data file. Flash-EPROM defective 	<ul style="list-style-type: none"> Upload valid crane data file Replace central unit
E52	Error in load chart file.	<ul style="list-style-type: none"> No valid data in the load chart file Flash-EPROM defective 	<ul style="list-style-type: none"> Upload valid load chart file Replace central unit

Error code	Error	Cause	Elimination
E53	Wrong setup of min. analog inputs length1, angle1, pressure1	<ul style="list-style-type: none"> Analog input not supported 	<ul style="list-style-type: none"> Setup correct Flag in in DGA 6.i.2
E56	Error in crane data file.	<ul style="list-style-type: none"> No valid data in the crane data file during calibration. Flash-EPROM defective 	<ul style="list-style-type: none"> Restore or upload valid crane data file Replace central unit
E57	Error in buffered data file.	<ul style="list-style-type: none"> Buffered data file does not contain valid data. Flash-EPROM defective 	<ul style="list-style-type: none"> Reset system Replace central unit
E61	Error in the CAN bus data transfer for all CAN units	<ul style="list-style-type: none"> CAN Bus cable between the central unit and the sensor unit defective or not connected. 	<ul style="list-style-type: none"> Check the connection between the central unit and the sensor units
		<ul style="list-style-type: none"> Can bus port in the central unit defective 	<ul style="list-style-type: none"> Replace the central unit
		<ul style="list-style-type: none"> Short circuit in a CAN Bus cable 	<ul style="list-style-type: none"> Replace Can Bus cable
E62	Error in the can bus data transfer of the pressure transducer sensor unit	<ul style="list-style-type: none"> Cable between the central unit and the sensor unit defective. 	<ul style="list-style-type: none"> Check the cable to the sensor unit
		<ul style="list-style-type: none"> Can bus port in the central unit defective 	<ul style="list-style-type: none"> Replace the central unit
		<ul style="list-style-type: none"> Can bus port in the sensor unit is defective 	<ul style="list-style-type: none"> Replace the sensor unit
		<ul style="list-style-type: none"> Sensor unit is defective 	<ul style="list-style-type: none"> Replace the sensor unit
E63	Error in the can bus pressure transducer sensor unit	<ul style="list-style-type: none"> The analog values of the sensor unit are invalid 	<ul style="list-style-type: none"> Replace the sensor unit
E64	Error in the can bus data transfer of the length/angle sensor unit	<ul style="list-style-type: none"> See E62 	<ul style="list-style-type: none"> See E62
E65	Error in the can bus length/angle sensor unit	<ul style="list-style-type: none"> See E63 	<ul style="list-style-type: none"> See E63
E66	Error in the data of the digital I/O MENTOR	<ul style="list-style-type: none"> PDB variable invalid 	<ul style="list-style-type: none"> Change system software Change MENTOR
E67	Error in the can bus data transfer of the digital I/O external module	<ul style="list-style-type: none"> PDB variable invalid 	<ul style="list-style-type: none"> Connect digital I/O external CAN module
E84	Wrong rigging condition.	<ul style="list-style-type: none"> The selected rigging condition is not contained in the crane data file. 	<ul style="list-style-type: none"> Select another rigging condition Check the programming in the crane data file.
E85	Error in the radius determination	<ul style="list-style-type: none"> The computed radius is too small (negative deflection) 	<ul style="list-style-type: none"> Check the programming in the crane data file.
E89	Operating mode switchover with load.	<ul style="list-style-type: none"> The operating mode on the console has been switched over with the boom loaded. 	<ul style="list-style-type: none"> Select operating mode without load on the boom
E98	LMI watchdog activated	<ul style="list-style-type: none"> LMI processing time limit exceeded 	<ul style="list-style-type: none"> Reset system Connect PC terminal and watch error messages
EAB	Short circuit in the A2B switch circuit (not with radio A2B)	<ul style="list-style-type: none"> Short circuit in the A2B switch 	<ul style="list-style-type: none"> Replace A2B switch
		<ul style="list-style-type: none"> Short circuit in the cable to the A2B switch 	<ul style="list-style-type: none"> Replace cable to the A2B switch

Error code	Error	Cause	Elimination
EAC	A2B switch circuit disconnected (not with radio A2B)	<ul style="list-style-type: none"> • Disconnected cable in the A2B switch • Disconnected cable to the A2B switch 	<ul style="list-style-type: none"> • Connect or replace cable in the A2B switch • Connect or replace cable to the A2B switch
EAD	No valid A2B switch status	<ul style="list-style-type: none"> • Sensor wrong function • CAN bus delay • Radio telegram delay module (radio A2B) • Radio telegram ID is invalid 	<ul style="list-style-type: none"> • Replace A2B switch • Replace cable to the A2B switch • Replace battery of radio module (radio A2B) • Setup ID in DGA12.9
EDB	Datalogger setup error	<ul style="list-style-type: none"> • Setup of the datalogger is cleared (ser. crane data file or battery buffered RAM) 	<ul style="list-style-type: none"> • transfer data and setup datalogger again
EDC	Datalogger watchdog activated	<ul style="list-style-type: none"> • datalogger processing time limit exceeded 	<ul style="list-style-type: none"> • Reset system • Connect PC terminal and watch error messages
EDD	Battery empty	<ul style="list-style-type: none"> • Battery check detected a low voltage of the battery 	<ul style="list-style-type: none"> • change batterie, after this setup of RTC
EDE	Record lost	<ul style="list-style-type: none"> • Not possible to save data because other task saves data at the same time 	<ul style="list-style-type: none"> • Message disappears after a few seconds
EDF	Flash block full	<ul style="list-style-type: none"> • Not possible to save any more data 	<ul style="list-style-type: none"> • Message disappears after a few seconds
EFD	LMI Watchdog extra time	<ul style="list-style-type: none"> • a funktion needs more than 0.5 sec, e.g. Flash PROM write 	<ul style="list-style-type: none"> • Message disappears after a few seconds

Note:

If a fault message is displayed that is not included in the present list, then please contact your local Hirschmann Customer Service. > www.hirschmann-ac.de <

17 TROUBLESHOOTING MOISTURE

The PAT iFLEX LMI contains electronic components in various locations, such as central unit, sensors, junction boxes etc. These internal components cannot be designed to withstand exposure to moisture over a longer period of time. For this reason, the housings of the components are water protected according to IP 65. If you find water or moisture inside any of the housings, the source for the water ingress has to be detected and corrected to ensure proper operation.

There are two major possibilities for the occurrence of excessive moisture inside an enclosure:

- Water ingress
- Condensation

This outline gives instructions for detecting the cause for excessive moisture by using simple troubleshooting methods and how to prevent the moisture ingress from happening again.

17.1 WATER INGRESS

There are different possibilities for water ingress. It is possible to find out the source of water ingress by going through the following steps and ruling out one possibility after the other until the cause is identified:

1) Spray Cleaning

The enclosures used for the PAT LMI system are water protected to IP 65. This means protection against the environment, such as rain. However, through the use of spray cleaner at short distances, it is possible to force water through the gasket or strain relieves. For this reason, avoid spraying any components from short distances with spray cleaners. Convey this fact to any member of a maintenance crew.

2) Missing / Loose Screws

All screws have to be present and to be equally tight to ensure water protection of the enclosure. If there are screws missing, replace them. If no screw is missing, check the tightness. If any were loose, then open all screws and then re-tighten them equally.

3) Bent Lid

An enclosure will only seal correctly if the lid is not bent. To check this, loosen all screws of the lid, take the lid off the box and visually inspect it for deflection. If the lid is bent or damaged, it needs to be replaced. Try to determine what has caused the lid to be bent and eliminate the reason for that. Order a new lid through your PAT representative.

4) Defective Gasket

The gasket underneath the lid seals the unit. The gasket needs to be in good condition in order to seal correctly. If the gasket is torn, brittle or severely bent, it needs to be replaced. Order a new gasket through your PAT representative.

5) Loose Strain Relieves

The strain relieves allow cabling to enter the box without allowing water to enter it. The strain relieves have to be correctly tightened in order to do this. Check the tightness by taking the external cable into one hand and carefully trying to turn it. If the internal wires turn with the outer cable, the strain relief is loose. Get a new grommet (insert) through your PAT representative and replace the existing one with the new one. Tighten the strain relief correctly. Note: Whenever a strain relief is opened, i.e. to replace a cable, a new grommet needs to be used. Never re-use any grommet or the strain relief will not seal properly!

6) Water Entry Through External Cabling

Even with a tight strain relief, water may still enter the box through the inside of the cable. In this case, you have to find out why and where water enters the cable. Look for damages to the cable itself and inspect the opposite side of the cable. In example, if the cable comes from a connector that is full of water, the water will run through the inside of the cable and fill up the central unit, too.

17.2 CONDENSATION

In a climate with high humidity and rapidly changing temperatures, condensation can happen inside any enclosure, usually the larger the volume of the box, the more likely. In this case, water drops build up on the inner components when humid air is trapped inside the box. With condensation, water tightness is not a problem – the box is sealed just fine, which is what prevents the trapped air from exiting the box. There are two ways to deal with condensation:

- If the volume is very small, a desiccant bag might be able to soak up the air's humidity.
- If the effect is more severe, the only way to get rid of this effect is then to give the box the ability to breath without sacrificing its water tightness. Contact your PAT representative for breathing elements to than can be added to the box and will help to reduce the effects of humid climates.

Version	Date	Modifications	Name
Rev. A	2007-08-17	First Issue for Grove RT and TM cranes iFLEX2 with iSCOUT expert compact Application base: Grove RT 530 expert compact V 1.04 / 20070511 – © HAC GmbH - 34230104	Konopka